



Expertise – Passion – Automation



## **Innovations 2017/18**

Boosting your competitiveness,  
connecting with you

# Innovation – Boosting your competitiveness, connecting with you

## **Breaking the rules - Connecting with others**

This year, to introduce our Innovations catalogue we have taken inspiration from the runaway success of Pokemon Go. Niantic, a Nintendo spin-off. It takes one of the trendiest technologies, augmented reality, thrusts it into our daily lives, and pushes us out of our comfy homes to hunt down pokemon. They broke the rules.

What's more, analysts suggest that the most powerful source of fun in the game's design is how it cultivates social engagement; players are motivated to communicate with one another, engaging in a deeply collaborative (instead of competitive) game. The collaborative aspects of the game broaden its appeal.

In pokeland, in business, and in life, the more you experience, the more you get connected: the more you engage. There can be risks in the absorption of a given technology, but investing in building relationships with real people, in connecting, is always beneficial: we all like connecting.

## **Connecting with you**

At SMC, communication with our customers is part of the essence of who we are.

We work to enhance our customers' productivity, by understanding their business; we get to understand their daily challenges by talking with them. With you. Often.



## Innovation – Evolution – Evolution means working close to you to boost your competitiveness

According to the Frost & Sullivan Visionary Innovation Group the tech trends for 2017 include: “The Mainstreaming of Augmented Reality for B2B”, “Cognitive as the new smart”, “Data-as-a-Service Explosion” and “IoT Pivots to Sentient Tools”.

All these great technological innovations and evolutions put a world of possibilities into our hands to increase our efficiency and competitiveness. The challenge is to understand them, to see how they fit into the world of automation and make them work to our advantage.

We believe the invisible thread that knits everything together lies in connection, in communication. That’s why nowadays trends like collaborative innovation are prospering and why probably the biggest trend in 2017 will be social messaging: we want to talk.

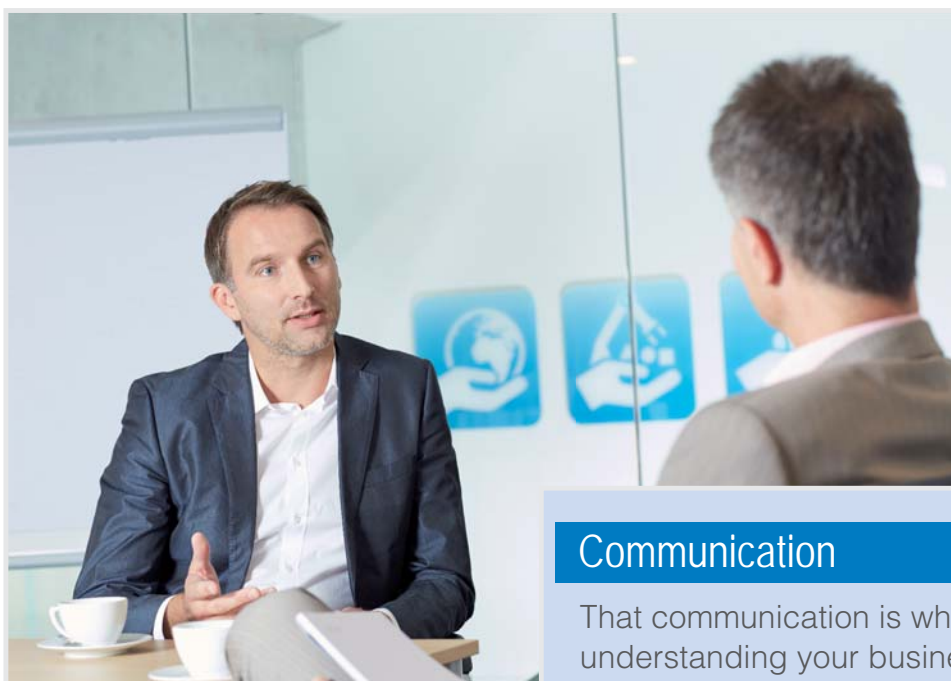

### Communication

That communication is what makes us capable of understanding your business, your daily challenges, and is what helps us evolve in providing you with a holistic support service in order to boost your competitiveness. It starts with you and ends with you; for you.

The following pages contain our main innovations from the past year, but remember that our real innovation is connecting with you.

Our stated commitment with you, as the main cover of this catalogue states, is to boost competitiveness. A higher level of competitiveness involves bettering the productivity, and increasing efficiency.



## 14 Efficiency starts with an E for Energy

### We are fluent in (Energy) Efficiency

We evolve to explore new inroads in efficiency. We enjoy engaging in easing up your expenses. We are exigent with ourselves in order to entrust our best to your; our expertise. So as to equip you with the engine to embark on energy efficiency.

“E” is a paramount and versatile letter, and we move comfortably around it. ▶▶

“If you are ready to talk (energy) efficiency, so are we.”



## 42 OEE or, if you prefer, the road to perfect production

### We talk “Productivity”

Given that good communication starts by talking the same language, we have learned how to talk “Productivity”.

We reckon it is not about individual automation components, but about their role in machine productivity or, in OEE terms, how they positively impact diminishing the 6 losses. ▶▶

“Shall we start talking?”



## 80 Efficiency, or just making your life more pleasant

### Over 20 e-Tools to make your design experience more pleasant and efficient

In the past months, we have released up to 12 new online tools and have upgraded some of the existing ones. With more than 20 support e-tools, free of charge, we are sure you will find good support in them. ▶▶

“Working close to you sometimes means providing you with the necessary tools for you to work and design on your own.”

# Index

## P. 4 Innovation – Boosting your competitiveness...

### VALVES

#### P. 6

ISO 13849-1 Safety Standard Compliant Valves **VP/VG**

#### P. 8

3 Port, 3 Position Valve **VEX3**

#### P. 9

5 Port Solenoid Valve **VQC4000/5000**

#### P. 10

5 Port Solenoid Valve **SY3000/5000/7000**

#### P. 12

Fieldbus System, EtherNet/IP™ Compatible **EX600-SEN**

#### P. 13

Fieldbus System, EtherNet/IP™ Compatible **EX260-SEN**

## P. 14 Efficiency starts with an E for Energy

### ACTUATORS

#### P. 16

Compact Guide Cylinder **JMGP**

#### P. 18

Compact Cylinder **JCQ**

#### P. 20

Tie-Rod Air Cylinder **JMB**

#### P. 21

Round Air Cylinder **JCM**

#### P. 22

ISO 15552 Profile & Round Tube Tie-Rod Cylinder **C96/CP96**

#### P. 24

Air Slide Table **MXQ-Z**

#### P. 26

Air Cylinder **CG1**

#### P. 27

Compact Slide Table **MXH-Z**

#### P. 28

Micro Clamp Cylinder **CKZM16-X2800/X2900**

#### P. 29

Cylinder Speed Checker **IN574-95/-73**

#### P. 30

Magnet Gripper **MHM-X6400**

### AIR LINE

#### P. 32

Modular F.R.L. Units **AC-B**

#### P. 34

Regulator, Precision Regulator **IR□200-A, IR□000-A**

#### P. 35

3.0 MPa High Pressure Electric-Pneumatic Regulator **ITVH**

#### P. 36

Clean Exhaust Filter **SFE**

#### P. 37

Filter Regulator, Special Specifications **AW-X2622**

### PIPING

#### P. 38

Moisture Control Tube **IDK**

#### P. 39

Flat Tubing **TU, TUS & TUZ**

#### P. 40

Speed Controller **AS/AS-FS**

#### P. 41

Metallic Speed Controller with One-touch Fitting **AS-X737**

## P. 42 OEE or, if you prefer, the road to perfect production

### INSTRUMENTATION

#### P. 44

Fan Type Ionizer **IZF**

#### P. 46

Desktop Duster Box **ZVB**

#### P. 47

3-Colour Display Digital Flow Switch **PFMC**

#### P. 48

High Precision Digital Pressure Switch **ZSE20(F)/ISE20**

#### P. 50

Pressure Sensor for General Fluids **PSE570**

#### P. 51

Digital Gap Checker **ISA3**

#### P. 52

Heat Resistant Solid State Auto Switch **D-M9J**

#### P. 53

Trimmer Auto Switch Sensor Unit **D-M9K**

#### P. 54

Thermo-Chiller, Compact Type **HRS**

#### P. 55

Thermo-Chiller, Basic Type **HRSE**

#### P. 56

Thermo-Chiller **HRSH**

#### P. 58

Peltier-Type Chiller, Thermo-con/Rack Mount Type **HECR**

#### P. 60

Peltier-Type Thermoelectric Bath **INR-244**

### PROCESS VALVES

#### P. 61

2/3 Port Media Separated Valve **LVMK20/200**

#### P. 62

High Purity Valve for Organic Solvents Air or Manually Operated **LVA/LVH**

#### P. 63

2 Port Solenoid Valve / Air Operated for Dust Collector **VXF**

#### P. 64

Angle Seat Valve for Steam, Air and Heated Water **VXB**

#### P. 66

High Speed 2 Port Valve **SX10**

#### P. 68

Pilot Operated 2 Port Solenoid Valve for Steam / Zero Differential Pressure Type **VXS**

### VACUUM

#### P. 69

Vacuum Filter **AFJ**

#### P. 70

Vacuum Pad with Ejector **ZHP**

#### P. 72

Vacuum Pad with Grooves **ZP3E**

#### P. 73

Non-Contact Gripper **XT661**

#### P. 74

Vacuum Unit, Vacuum Ejector & Vacuum Pump System **ZK2**

#### P. 76

Body Ported Type Vacuum Ejector **ZH**

#### P. 77

Stainless Steel Vacuum Ejector **ZH-X267**

#### P. 78

Aluminium High Vacuum Angle Valve **XL□-2**

#### P. 79

Normally Closed High Vacuum Solenoid Valve **XSA**

## P. 80 Efficiency, or just making your life more pleasant

### ELECTRIC ACTUATORS

#### P. 82

High-Rigidity Electric Actuator, Slider Type **LEJ**

#### P. 84

Electric Actuators, Motorless Type **LEF, LEJ, LEY (G)**

#### P. 85

Rod Type Electric Actuator, Dust/Drip Proof Specification **LEY-X5**

#### P. 86

Low Profile Guide Slider Electric Actuator **LEM**

#### P. 87

Step Motor Controller **JXCE1/91/P1/D1**

#### P. 88

4 Axis Step Motor Controller **JXC73/83/93**

#### P. 90

AC Servo Motor Controller, Pulse Input Type **LECS**

#### P. 91

AC Servo Motor Driver, MECHATROLINK Compatible **LECY**

#### P. 92

Card Motor **LAT3**

#### P. 93

Card Motor Controller **LATCA**

# Your safety in our focus

## ISO13849-1 Safety Standard Compliant Valves **VP/VG Series**

Main benefits



- **Feel safe, comply with ISO 13849-1**
- **Facilitate the construction of your safety function** – SMC's safety valve data are integrated into SISTEMA free software tool
- **React quickly** – Optimum response time and high release flow rates
- **Smoothly safe** – Integrated soft start-up function.

Residual pressure release valve with detection of main valve position  
Safety Standard ISO13849-1 for category 2.

VP□42-X536 Series



Dual residual pressure release valve with detection of main valve position

- Safety Standard ISO 13849-1 for categories 3, 4:
- VP□44-X538 Series: enclosure protection IP65
  - VG342-X87 Series: high flow rate 13000 l/min (ANR).

VG342-X87 Series

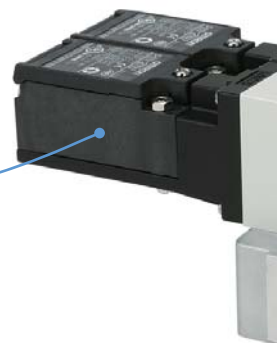

More information on the VP/VG series?



<http://VP-VG.smc.eu/en>



### The Expert's opinion:

*Machinery safety can be challenging; therefore SMC provides easy pneumatic safety concepts, ready to be integrated into your safety control system.*

MR. PATRICK WOTAWA, SENIOR STANDARDISATION & OPERATIONAL SAFETY EXPERT, SMC AUSTRIA

**New**

### Dual residual pressure release valve with detection of main valve position and with soft start-up function

- Safety Standard ISO13849-1 for categories 3, 4:
- VP□44-X555 Series: maximum operating pressure 0.7 MPa
  - VP□44-X585 Series: maximum operating pressure 1.0 MPa

### Integrated soft start-up function

It gradually increases the initial pressure of the pneumatic system, thus allowing a smoother start-up.

**New** VP□44-X555 Series  
VP□44-X585 Series

### Detection of main valve position

The detecting function of the main valve position detects a mismatch between the input signal and valve operation.

### Dual pressure release valves - redundant system

By having two valves the correct functioning of the whole system is ensured even if one of the valves fails to operate.

### Selectable operation, check valve and safety limit switch

- Operation: internal pilot, external pilot
- Limit switch: OMRON, Rockwell Automation.



OMRON



Rockwell Automation

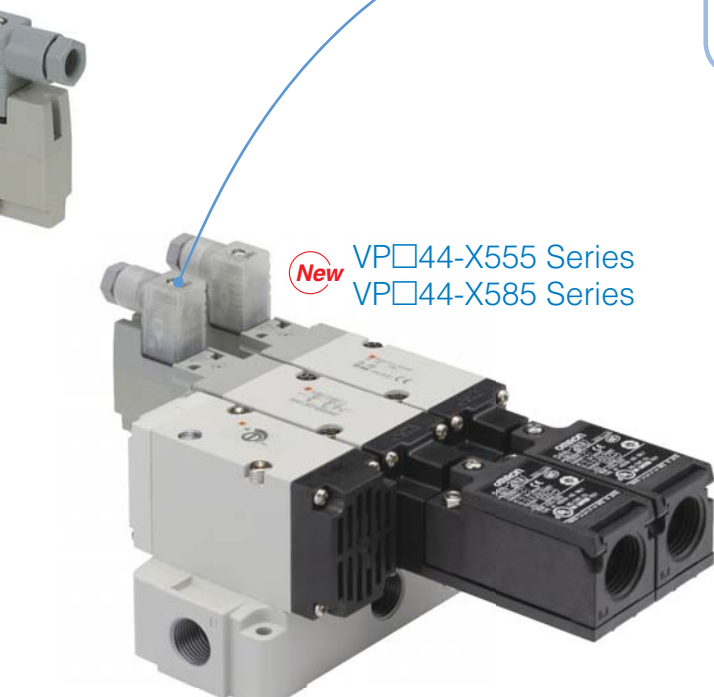

VP□44-X538 Series

### Application examples

- Applications involving risks such as in automatic machines, or involving risks for operators such as in pick and place applications
- Applications requiring a progressive start up such as in transporting operations.



# Entirely designed to consume less

## 3 Port 3 Position Valve **VEX3 Series**

Main benefits

- **Reduce your costs** – Low energy consumption design
- **Control your air circuit even without power supply** – 4 manual override options
- **Get multiple usage options** – 3 position centre-closed type.

Reduced power consumption: 1 W

Pilot solenoid or air operated options



3 position centre-closed type

With fewer valves, which require fewer connections, you get multiple usage options.

- **Intermediate stopping** of cylinders up to Ø 125 is possible
- **Acceleration or deceleration.**

Body ported, base mounted or manifold options

More information on the VEX3 series?



<http://VEX3.smc.eu/en>

3 Locking type manual override options

Locking slotted type (for grommet/plug connector)



Push-turn locking slotted type (for DIN terminal)

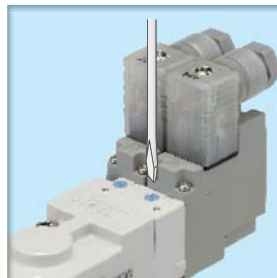

Push-turn locking lever type (for DIN terminal)

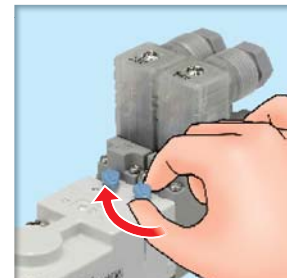

Non-locking type also available



# Flexible solution for large capacity requirements

## 5 Port Solenoid Valve **VQC4000/5000 Series**

### Main benefits

- **Introduce great capacity and versatility in your application**
  - New sizes, types and options
- **Achieve flexibility** – Plug-in unit as a single unit
- **Handle it easily** – Connector type manifolds and connectors whose entry direction can be easily changed
- **Get a robust and long-lasting valve** – Built-in strainer that prevents foreign matter from entering.

### Reduced power consumption

- Standard type: 0.95 W
- Low wattage type: 0.4 W.

### New V100 pilot valve

New strainer built into the V100 pilot valve flow supply passage

### Connector type manifold

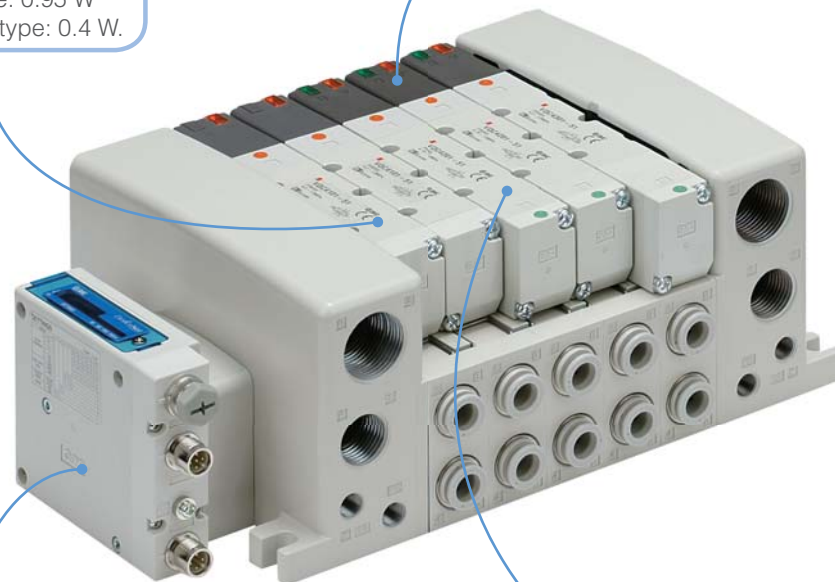
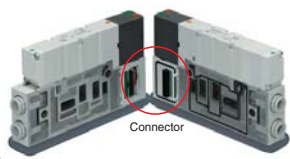

### Extensive range of protocols available

(Enclosure IP67 compliant)



### Compact and large flow capacity

- VQC4000: 25mm pitch, Q [l/min (ANR)]: 1958 (Possible to drive cylinders up to Ø 160)
- VQC5000: 41 mm pitch, Q [l/min (ANR)]: 4350 (Possible to drive cylinders up to Ø 180).

### Connector entry direction can be changed with a single push (F/P kit)

The connector entry direction can be changed from the top to the side by simply pressing the manual release button.

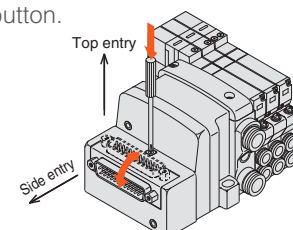

More information on the VQC4000/5000 series?



<http://VQC4000-5000.smc.eu/en>

# The most versatile all-purpose valve

## 5 Port Solenoid Valve SY3000/5000/7000 Series

Main benefits

- **Improve your productivity** – Outstanding reliability and reduction in cycle time
- **Save on installation costs and assembly time** – Remarkable flexibility in design
- **Cut your costs** – Air savings by driving higher capacity cylinders and using mixed mounting valves
- **Simplify machine use and operation** – Unique and compact manifold: vacuum suction and release in a single unit.

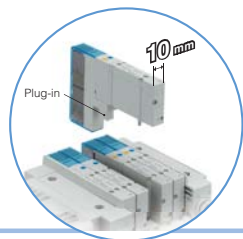

Compact size and high flow

As narrow as 10 mm wide (SY3000).

Flow characteristics:

Speed	Series	Suitable cylinder									
		ø6	ø10	ø16	ø20	ø25	ø32	ø40	ø50	ø63	ø80
300 mm/s	SY3000	[Flow range bar from ø6 to ø50]									
	SY5000	[Flow range bar from ø10 to ø63]									
	SY7000	[Flow range bar from ø16 to ø80]									



Integration of wiring, piping and operation on one side

Multiple layer is available as an option. This saves space in the lateral direction

Bottom ported available

This reduces the footprint and enables the separation of electrical and pneumatic connection.



The Expert's opinion:

*Its most reported benefit is its cost-effectiveness. Smaller sizes hold the capacity of larger ones. Now cost-effectiveness is extended to vacuum applications.*

MR. KURT MEILI, TEAM LEADER PRODUCT MANAGEMENT, SMC SWITZERLAND.

**Flexible piping – direction, size and type of piping can be changed**

Possible to mount the piping on top, on the side and mixed

**Back pressure check valve**

This prevents cylinder malfunction caused by the exhaust from other valves.



**Mixed mounting is possible in the same manifold**

Different sizes (SY3000/5000 or SY5000/7000) can be mixed. Possible to reduce installation space, the number of serial units and wiring.

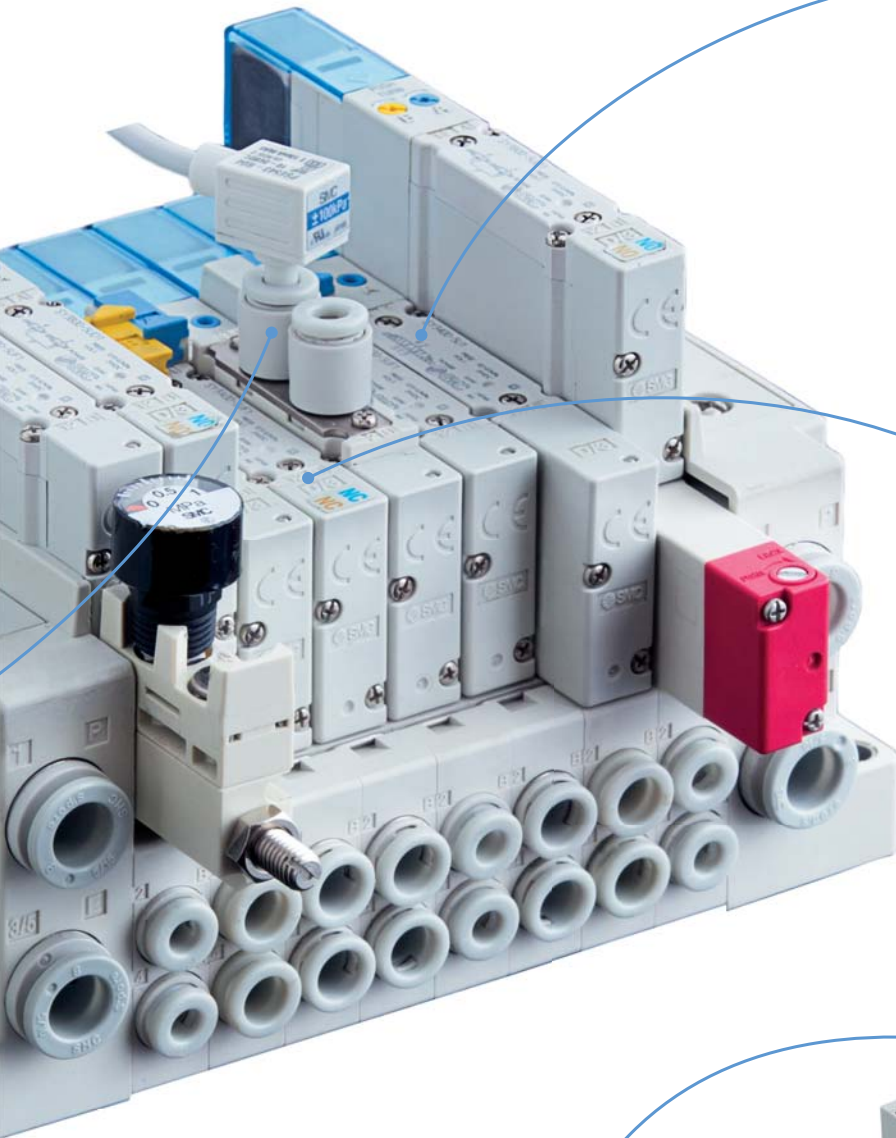

**Simple and quick valve replacement**

Easy replacement compared to stacking manifold types.



**New**

**Vacuum release valve with restrictor**

This allows control of both vacuum suction and release with a single valve unit, and prevents the workpieces from blowing-off thanks to gentle expulsion.

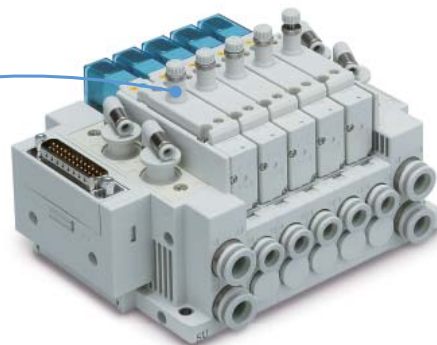

More information on the SY series?



<http://SY.smc.eu/en>

# Increase the capabilities of your communications

## Fieldbus System, Dual Port Serial Interface Unit EtherNet/IP™ Compatible EX600-SEN3/4 Series

Main benefits

**New**

- **Ensure communication at all times** – DLR topology
- **Obtain greater flexibility** – Availability of both digital and analogue input/output units
- **Enhance efficiency with easier maintenance** – Self-diagnosis function and LED display
- **Reduce installation and wiring time** – Joint type connection method plus SPEEDCON compatible connectors.



### Self-diagnosis function and LED display

- Possible to ascertain the maintenance period and identify the parts that require maintenance
- In combination with the **Handheld Terminal**, it allows setting parameters and monitoring I/O signals.



### Centralised multipoint fieldbus system for digital and analogue I/O

- Up to 9 I/O units, either digital or analogue, can be connected in any order
- Possible to connect various input and output devices to the digital/analogue I/O units.



**New**

### Dual port SI Unit (EtherNet/IP™)

- No loss of communication occurs, despite having a disconnected location thanks to the DLR topology

### Supports Quick Connect™ function:

- Supports Quick Connect™ function: In the case of a tool changer, communication can be established in approx. 0.5 seconds

### Built-in Web Server Function:

- Status checks and settings can be performed on a general purpose web browser.

Compatible protocols (IP67 enclosure protection)



More information on the EX600-SEN3/4 series?



<http://EX600.smc.eu/en>

# The cost-effective solution for your communications

## Fieldbus System, EtherNet/IP™ Compatible **EX260-SEN Series**

### Main benefits

- **Cost savings** – Through a cost-effective serial interface solution
- **Space savings** – With product equipment size reduction thanks to compactness and cabling with daisy-chain wiring communication
- **Easy operation setting** – Leads to labour savings
- **Quick connection with reduced installation and start times.**

### Valve output system

Output device for driving 5 port solenoid valves

- Drives up to 32 solenoids, and up to 24 stations
- SY3000/5000/7000 manifold solenoid valve compatible.

Suitable for process control and other industrial applications

**EtherNet/IP**

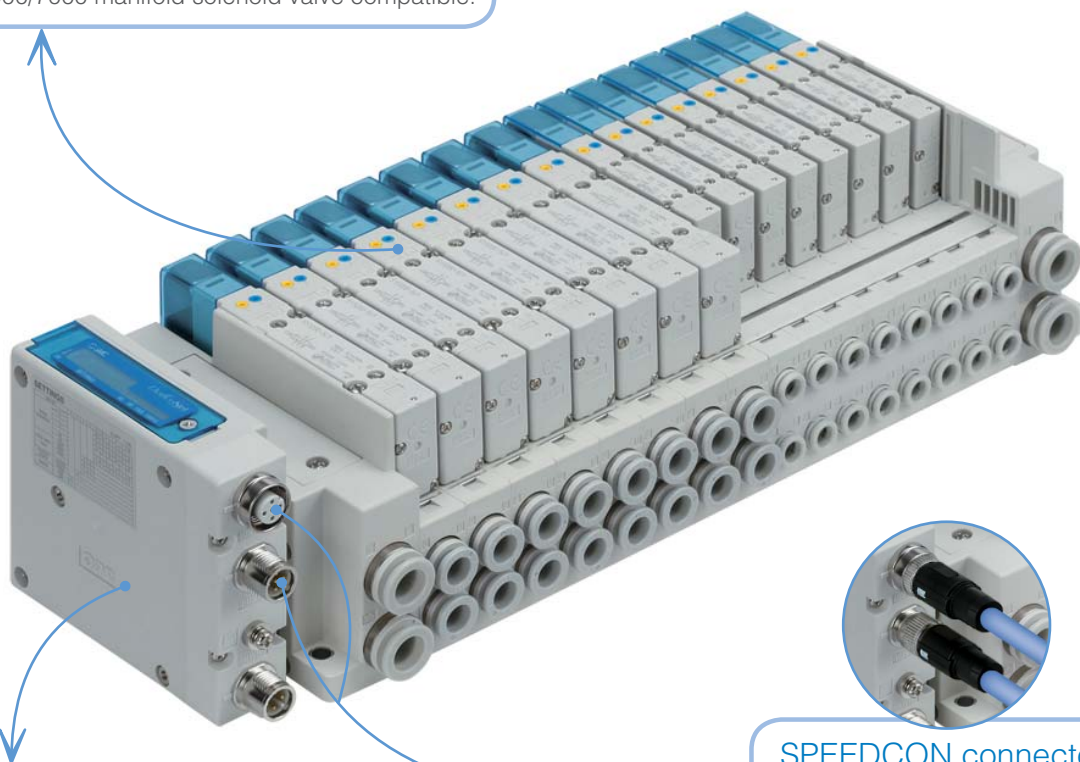

### Internal terminal resistor

ON/OFF switching is possible with an internal terminating resistor.

### SPEEDCON connectors compatibility

– Just insert and rotate 1/2 turn  
– IP67 enclosure protection.



### Daisy-chain wiring communication

– Daisy-chain results in branch connector savings without having to use branch connectors  
– Wiring and piping possible from the same direction

- IP67 enclosure protection
- EX260 compatible with other fieldbus protocols



**PROFI**® **DeviceNet** **PROFI**® **NET**

**EtherCAT** **CC-Link**

More information on the EX260 series?



<http://EX260.smc.eu/en>

# Efficiency starts with an E for Energy

There was a time when Energy Efficiency was relegated to the realm of “low priority activities.” Energy usage was considered as an unavoidable cost, and the reduction of greenhouse emissions and global warming a distant sound. For many, those days are gone.

European leaders finally found a way to push forward the 20 / 20 / 20.

To make it real and not the dream of a few. Legislating the way to it with EU Directive 2012/27/EU. “Under Article 8 of the EU-EED, large enterprises employing at least 250 persons or exceeding an annual turnover of €50 million and having a balance sheet above €43 million are required to either execute energy audits of their operations, carried out by accredited auditors at least every 4 years, or to implement an energy management system according to ISO 50001 or equivalent.”

Both solutions provide the identification of existing energy saving potential, resulting in a decrease in energy consumption, greenhouse gas emissions and thus reducing the cost associated with that consumption.

## GENERAL QUOTE:

“Some users of compressed air have the notion that compressed air is a cheap energy source because the air we breathe is free and abundant. In fact, compressed air is one of the most expensive sources of energy”.

## How do you feel about DIY? We love it

Since it started to be mandatory, we have found that many of our customers do prefer complying with the EU Directive through the implementation of the ISO 50001, primarily because the emphasis is on continuous improvement, rather than externally imposed targets. At the end of the day, it is more like a “DIY activity”, with the great flexibility this implies. Furthermore, for those companies who have already implemented ISO 9001 and ISO 14001, it makes sense to follow the ISO 50001 route.

In the same vein, we cannot but support a project involving continuous improvement and crafted solutions. Subsequently, we naturally go along with our customer through the ISO 50001 process.

## The Efficiency continuum

If we talk about continuous improvement, we must talk about the Deming cycle, more popularly known as the PDCA wheel. The constant improvement applied to energy efficiency consists, broadly speaking, in analysis and measurement.

**PLAN** – Conduct energy review and establish a baseline of current energy consumption. Energy performance indicators (EnPIs) are then set, along with (achievable) objectives, targets and action plans.

**DO** – Implement the energy management action plans.

**CHECK** – Monitor and measure processes and the key characteristics of their operations that determine energy performance against the energy policy and objectives and report the results. Basically, this stage comprises the checking of the results obtained against the agreed objectives.

**ACT** – Take action to continually improve energy performance and the Energy Management System (EnMS)

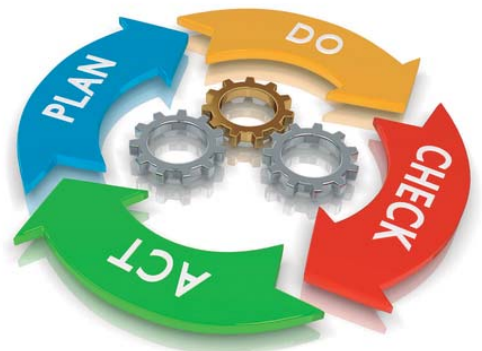

## Available soon – PF3A – A Digital Flow Switch to save energy

Flow control is necessary for promoting energy saving in any application. Saving energy starts from the numerical control of the flow consumption of equipment and lines and clarification of the purpose and effect.

- \* Digital 3-colour/2-screen display allows easy visualization.
- \* Flow ratio 100:1; Wide range of flow measurement with one product.
- \* Remote control is possible with accumulated pulse.



## Already available – ISE30A – A High-Precision Digital Pressure Switch to save energy

For benchmarking and trying to reduce the operating pressure of the machine or, if possible, of the entire factory.

- \* Digital 2-colour display allows easy visualization.
- \* Simultaneous copying - for up to 10 units.
- \* Power saving function, which reduces energy consumption by up to 20 %.

## Monitor & Measure: the essence of Energy Efficiency

Measure and monitor energy use to drive efficiency improvements; improve overall energy performance to cut energy costs and carbon emissions.

## We are fluent in (Energy) Efficiency

We evolve to explore new inroads in efficiency. We enjoy engaging in easing up your expenses. We are exigent with ourselves in order to entrust our best to your; our expertise. So as to equip you with the engine to embark on energy efficiency.

“E” is a paramount and versatile letter, and we move comfortably around it.

## From a monologue to a dialogue

Lately, we are experiencing a change in the conversations with our customers; we now increasingly discuss the contribution of our solutions to their energy efficiency plans.

Nowadays we find many customers request energy efficient solutions. The same solutions we have been presenting for years, are now actually in demand.

In essence, we are qualified to discuss our solutions in terms of their contribution to the process (energy) efficiency; because we fully understand how, when interacting in the different stages of production, they can lead to more efficient compressed air consumption.



**“ If you are ready to talk (energy) efficiency, so are we. ”**

# Fit for purpose - Maximum efficiency

## Compact Guide Cylinder **JMGP Series**

### Main benefits

- **Achieve cost-efficient machines** – By downsizing other components
- **Increase your productivity** – Improved cycle times due to the cylinder's lightness
- **Reduce the dimensions of your machine** – Highly compact
- **Gain great flexibility** – Possibility of piping in 4 directions and mounting on 3 different surfaces.

Compact and lightweight

Auto switches can be mounted directly without the need to use auto switch brackets

3 mounting options

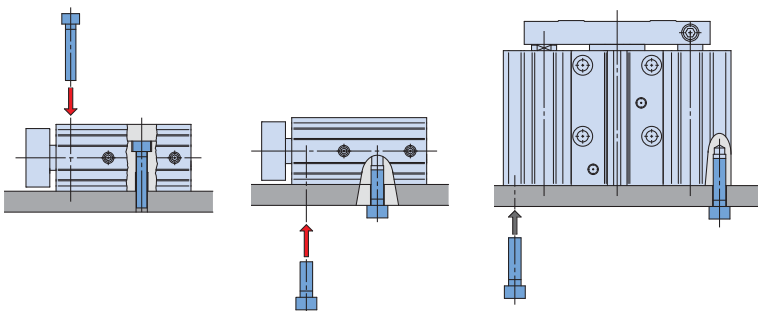

### The Expert's opinion:

*The space in this cylinder has been optimised to the last millimetre. It presents an amazing reduction in space and weight when compared to similar models.*

MR. ROBERTO RUBILIANI, PRODUCT MANAGER, SMC ITALY



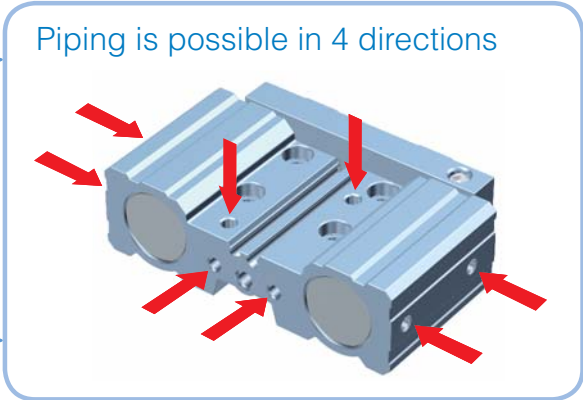

More information on the JMGP series?



<http://JMGP.smc.eu/en>

Application examples

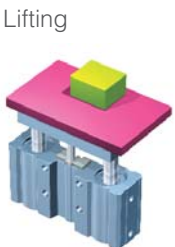
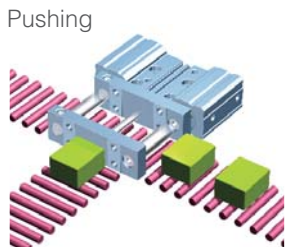

# Fit for purpose - Maximum efficiency

## Compact Cylinder **JCQ Series**

### Main benefits

- **Achieve cost-efficient machines** – By downsizing other components
- **Increase your productivity** – Improved cycle times due to the cylinder's lightness
- **Reduce the dimensions of your machine** – Highly compact
- **Get mounting flexibility** – Mount the auto switch on any of the 4 surfaces.

Compact and lightweight

Auto switches do not protrude beyond the body of the cylinder



### The Expert's opinion:

*Our engineers have designed this compact cylinder with weight and space savings in mind. Both help to reduce machine sizes, drive down costs and increase your productivity.*

Ms. ŠÁRKA TOMÁŠKOVÁ, PRODUCT MANAGEMENT - ISO CYLINDERS AND LINEAR ACTUATORS, SMC AUSTRIA



Auto switches can be mounted directly without the need to use auto switch brackets

Auto switches can be mounted on 4 surfaces

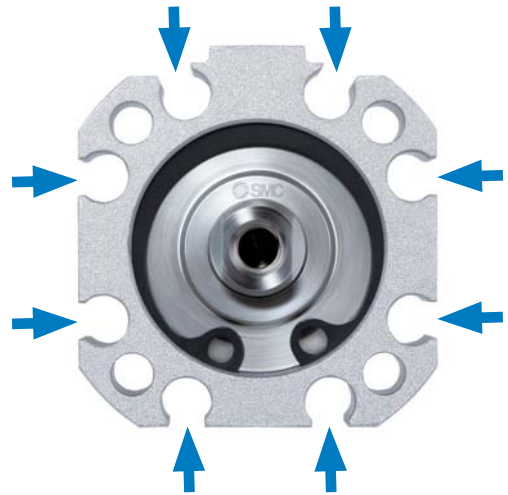

More information on the JCQ series?



<http://JCQ.smc.eu/en>

# Fit for purpose - Maximum efficiency

## Tie-Rod Air Cylinder **JMB Series**

Main benefits

- **Attain a machine that consumes less air** – Intermediate bore sizes available
- **Achieve cost-efficient machines** – By downsizing other components
- **Increase your productivity** – Improved cycle times due to the cylinder's lightness
- **Reduce the dimensions of your machine** – Highly compact.

Compact and lightweight



Intermediate bore sizes can be selected

JMB Ø 45



JMB Ø 56



JMB Ø 67



JMB Ø 85



More information on the JMB series?



<http://JMB.smc.eu/en>

# Fit for purpose - Maximum efficiency

## Round Air Cylinder JCM Series

### Main benefits

- **Achieve cost-efficient machines** – By downsizing other components
- **Increase your productivity** – Improved cycle times due to the cylinder's lightness
- **Reduce the dimensions of your machine** – Highly compact
- **Benefit from great detection possibilities** – Optimum design of the mounting band.

Compact and lightweight



### Good manageability and operability of the auto switch

- Easy to insert thanks to the mounting band
- There are no parts near the auto switch so its status is easy to determine through the indicator LED.



### Male and female rod ends available



More information on the JCM series?



<http://JCM.smc.eu/en>

# The ISO cylinder that adapts to you

## ISO 15552 Profile & Round Tube Tie-Rod Cylinder **C96/CP96 Series**

Main benefits

- **Adapt it easily to your application** – Many options and mounting brackets available
- **Shorten the cycle and cushioning time** – Double air and bumper cushion
- **Reduce the impact noise** – Bumper integrated at the stroke end
- **Make your machine lighter** – Lighter construction.



Minimum piston rod deflection enhances the accuracy levels of your machine



C96



Improved mounting accuracy ensures a secure position of the cylinder during machine operation

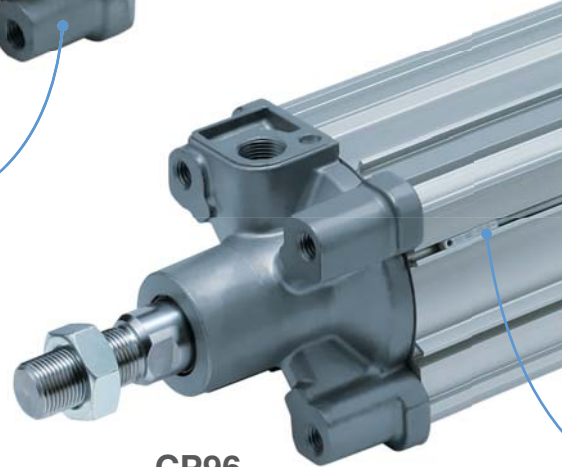

CP96

Many options available as standard

Non-rotating rod, double rod, rod boot, smooth cylinder, ATEX compliant cylinder, tandem cylinder, heat or cold resistant cylinder, cylinder with parts made of stainless steel, among others.

Various mounting bracket options

Mounting brackets can be combined according to the operating conditions: axial foot, rod and head flanges, centre trunnion, single and double clevis, pivot brackets, floating joint, rod clevis and piston rod ball joint.



The Expert's opinion:

*At SMC, we have been designing cylinders for 45 years; with the C(P)96 our engineers have designed the ISO that provides other engineers with maximum design flexibility.*

MR. MICHAEL LOSERT, COORDINATOR INDUSTRIAL APPLICATION CENTRE, SMC GERMANY.

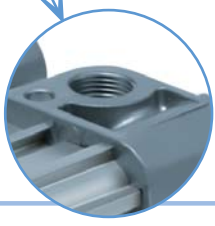
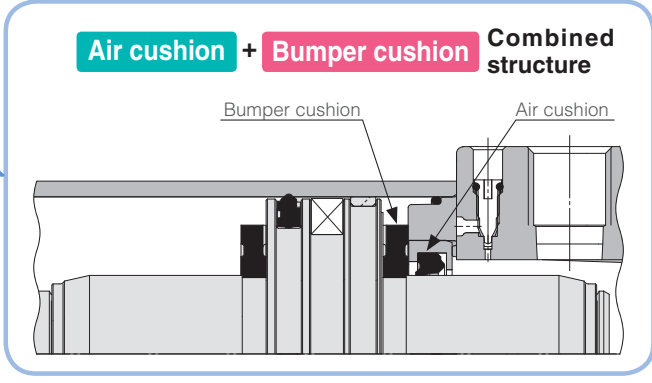

The easy adjustment of the cushion valve allows optimum control of the air cushion

Since the adjustment of the cushion valve is performed with a hexagon wrench key, even fine control can be easily accomplished.



Possibility to slide auto switches in from all four sides without the need to use auto switch brackets

More information on the C96/CP96 series?



<http://C96-CP96.smc.eu/en>

# Packed with features, simply the best

## Air Slide Table **MXQ-Z Series**

Main benefits

- **No distortions, oscillations or vibrations** – Due to the compact and low centre of gravity design
- **Energy saving** – If the MXQ□B type is used for downsizing
- **Reduced deflection** – As the stroke adjuster is positioned in the centre.

Reduced in height and weight with thinner table

- Thin table made of a special stainless steel
- Durable, high-strength material.



Various stroke adjusters

- Metal Stopper with Bumper
- Shock Absorber
- Rubber Stopper.



Double ported type MXQ□A

Increase flexibility of wiring and piping with piping ports and auto switch mounting grooves on both sides

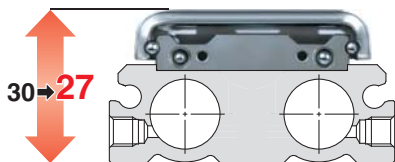

For MXQ12A

Low thrust with high rigidity type MXQ□B

Combination with a cylinder of one bore size smaller increases rigidity according to thrust. Possible to reduce in height

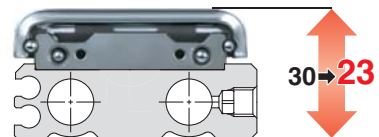

For MXQ8B



The Expert's opinion:

*As the pioneers of air slide table development, we can confidently say that these are the best products on the market today.*

MR. COLIN GIBSON, TECHNICAL MANAGER ACTUATORS GROUP, SMC EUROPEAN TECHNICAL CENTRE.





Round auto switches (D-M9□) can be mounted directly without spacer

**Many functional options**

- With buffer mechanism: protects workpieces and tools by eliminating impact at the extension stroke end
- With end lock: holds the cylinder's home position to prevent dropping of the workpiece even if the air supply is cut off
- Axial Piping: centralised piping in axial direction to maintain clear space around the body.

Allowable kinetic energy improved by reducing the weight of the movable parts

**Single side ported type MXQ□C**

Better visibility for auto switches. Indicator LED can be checked from one side when used with short stroke

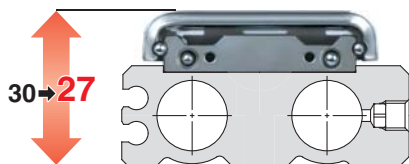

For MXQ12C

**Height interchangeable type MXQ□**

Height interchangeable with the existing MXQ series

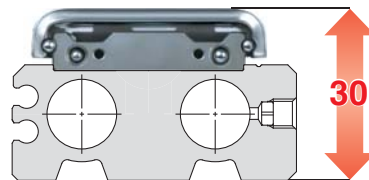

For MXQ12

More information on the MXQ-Z series?



<http://MXQ-Z.smc.eu/en>

# Basic Round Cylinder with a premium dash

## Air Cylinder **CG1 Series**

Main benefits

- **Shorter total length** – Using the female rod end
- **Reduced assembly and maintenance costs** – Thanks to the fine adjustment of the auto switch position by just loosening one screw
- **Simple construction and no foreign particle accumulation** – Thanks to the basic mounting with no trunnion mounting female thread.

Rod end styles

Styles suitable for the application can be selected.

Female rod end

Available as standard.

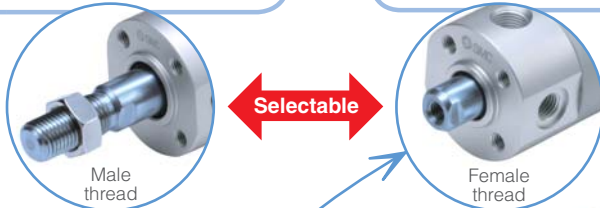

No trunnion mounting female thread added to basic type

No foreign matter accumulation due to the simple construction.

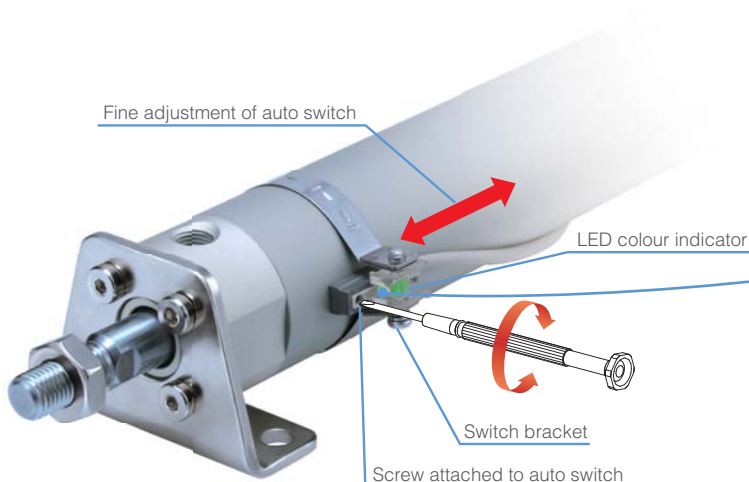

Easy fine adjustment of auto switch position

Fine adjustment of the auto switch position is possible by simply loosening the screw attached to the auto switch.

Transparent switch bracket improves visibility of the indicator LED

More information on the CG1 series?



<http://CG1.smc.eu/en>

# Ideal for long distance executions

## Compact Slide Table **MXH-Z Series**

### Main benefits

- **Longer distances to the workpiece** – Allowed thanks to the new high rigidity linear guide and to the increased allowable moment
- **Lightweight machines** – Due to its lighter construction
- **Minimum deflection** – At the extended position of the table because of its high travelling parallelism accuracy.

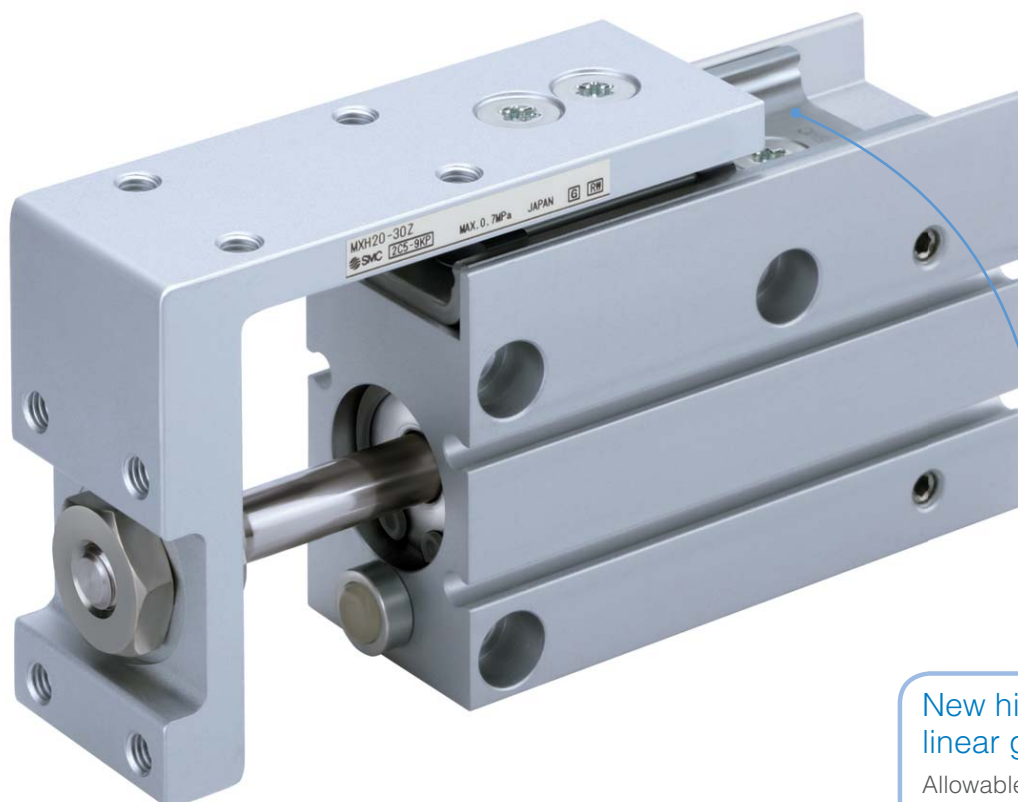

### New high rigidity linear guide

Allowable moment increased by up to 240%

### High travelling parallelism accuracy:

- 0.05 mm or less in strokes 5 to 30 mm
- 0.1 mm or less in strokes 40 to 60 mm

### Application examples

Precision adsorption

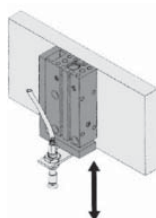

Parts transportation

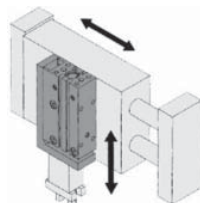

Positioning pin

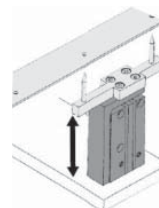

More information on the MXH-Z series?



<http://MXH-Z.smc.eu/en>

# Your mini but strong clamping solution

## Micro Clamp Cylinder **CKZM16-X2800/X2900 Series**

### Main benefits

- **Reduce the required space** – Lightweight and compact design
- **Handle with reliability** – High clamping and holding forces
- **Mount it easily** – Arm and mounting assembly added
- **Get a long-lasting solution** – The structure prevents dust from entering easily.

High holding force: 300 N

High clamping force

- CKZM16-X2800: 125 N
- CKZM16-X2900: 200 N

Compact and lightweight

- CKZM16-X2800: 250 g
- CKZM16-X2900: 330 g

Arm assembly and mounting assembly are added to clamp cylinder

Dust resistant construction

### Application examples

Clamping of workpiece

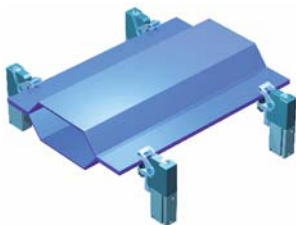

Gripper handling workpiece

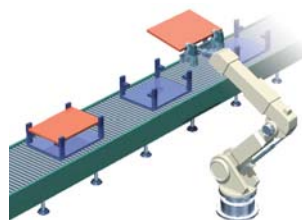

More information on the CKZM16 series?



<http://CKZM.smc.eu/en>

# Measure & Check for maximum cylinder efficiency

## Cylinder Speed Checker **IN574-95/-73 Series**

### Main benefits

- **Reduce labour time and overall hassle** – Measure and check, inspect and adjust easily with one single device. Check speed, cycle time and/or the operations per minute
- **Use & handle in a simple way** – Select the different modes with just one button. Furthermore, it is compact and lightweight
- **Read the screen even in dark environments** – The backlight provides good readability in poor lighting conditions.

### 3 different measurements in air cylinders

- Speed
- Cycle time
- Operation times per minute.



The light is switched on by pressing the "Light" button

It can be changed from one mode to another by simply pressing...

Automatic "power OFF" function after 15 minutes without operation

### Application examples

Cycle time measurement

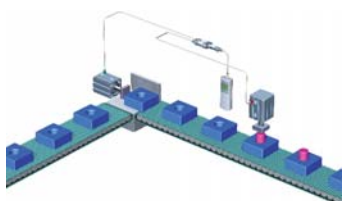

More information on the IN574-95/-73 series?



<http://IN574.smc.eu/en>

# Performs optimally, where others don't

## Magnet Gripper **MHM-X6400 Series**

### Main benefits

- **Improve your current handling solutions** – e.g. vacuum pads or grippers
- **Handle with reliability and safety** – Holding force up to 120 N plus it guarantees grasping of the workpiece even when the air is shut off
- **Increase your productivity** – Reduce your cycle times: residual holding force of 0.3 N or less
- **Get great usage flexibility** – Holding force can be adjusted by simply changing the bumper type.

Holding force up to 120 N

Holds workpieces even when air is shut off

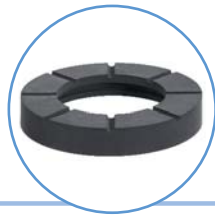

Holding force can be adjusted with a bumper with 3 types of thicknesses

- 6 mm
- 7 mm
- 8 mm



### The Expert's opinion:

*Very convenient solution to handle big metal panels, mainly in automation; problematic quality issues due to deformation are now virtually zero thanks to MHM.*

Ms. DAFNE PARIGI, PRODUCT MANAGER, SMC ITALY

Residual holding force 0.3 N or less

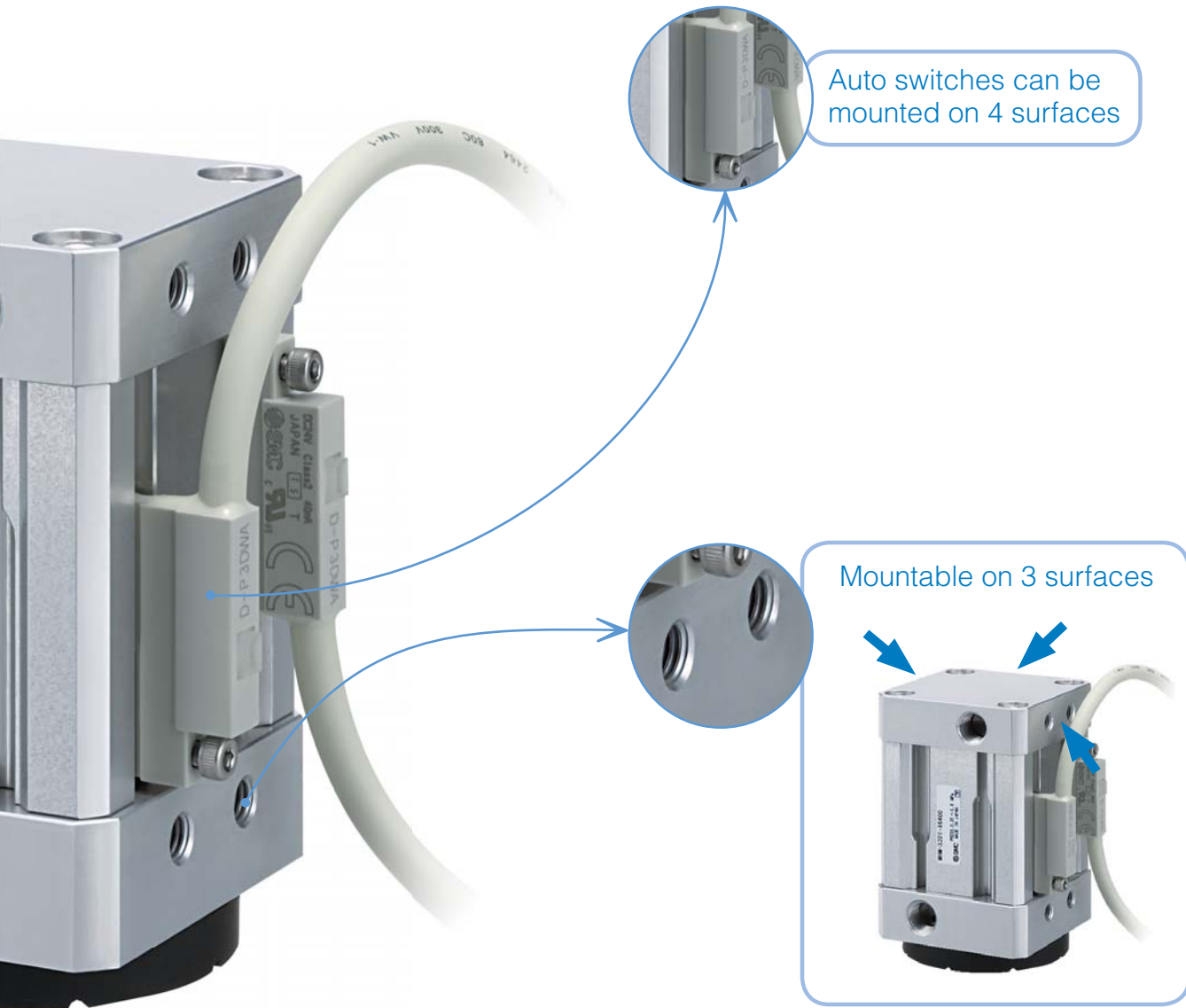

### Application examples

Application with requirement to support ferromagnetic workpieces including those with holes and uneven surfaces



More information on the MHM-X6400 series?



<http://MHM-X6400.smc.eu/en>

# It is different, that's crystal clear

## Modular F.R.L. Units **AC-B Series**

### Main benefits

- **Ease your maintenance work** – Transparent bowl guard plus no tools required for the maintenance
- **Check the pressure as you want** – Different pressure gauge options
- **Let it work with chemicals** – Optional bowls.

Transparent polycarbonate double layer structure bowl guard available, with 360° visibility, weight reduction and better resistance to rust or corrosion

- Possible to monitor the condensate inside the filter case and the remaining oil amount in the lubricator from anywhere
- Environmental resistance since the inner bowl is completely protected with a polycarbonate bowl guard.



**Transparent bowl guard**  
Material: Polycarbonate

**Inner bowl**  
Material: Polycarbonate



**Modular connection with a new bracket system**

Initial tightening by hand.

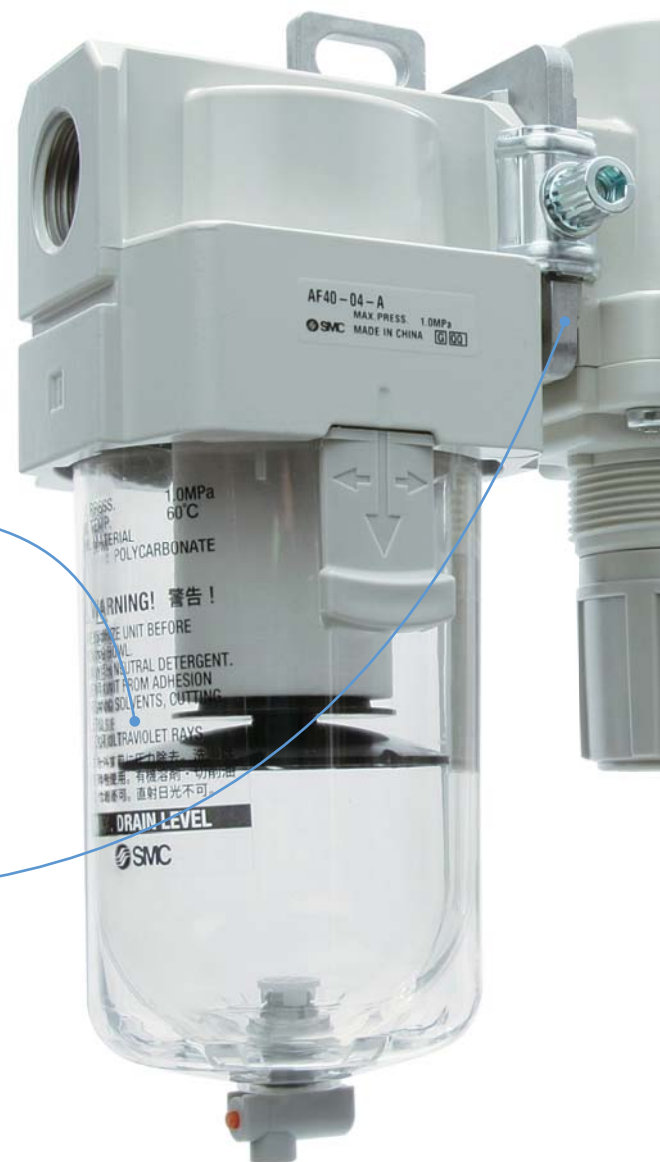

### The Expert's opinion:

*Our worldwide leadership in pneumatics means that you can be sure that we provide a truly first class FRL unit.*

MR. RICHARD DRIVER, TECHNICAL MANAGER VALVES AND AIR EQUIPMENT, SMC EUROPEAN TECHNICAL CENTRE.



## Integrated and selectable pressure gauges and switches



Round type pressure gauge



Square embedded type pressure gauge



Digital pressure switch



## More visual and useful bowl locking system

- Adapted convex body
- Coincident with the bowl lock button.

## In-bowl assembled element construction – the element and the bowl are in one piece

- Reduced time and space for maintenance
- Easy and quick in-hand replacement / manipulation
- Compact with height reduction and lightweight

## Interchangeability with existing AR series by panel mounting

### Bowl material selectable

- Polycarbonate – standard type
- Metal type – with and without level gauge
- Nylon.

More information on the AC-B series?



<http://AC-B.smc.eu/en>

# Energy efficient regulators with multiple savings

## Regulator, Precision Regulator IR□200-A, IR□000-A Series

### Main benefits

- **Save energy** – Air consumption reduction (for IR□200-A no air consumption) and improved flow rate
- **Save space** – Overall machine size kept to a minimum
- **Achieve flexibility and make your ordering easy** – Wide range of standardised options
- **Adapt it easily** – Mounting interchangeability with existing series.

### Original design with no fixed throttle

This results in:

- **Air consumption reduction**, with no air consumption at all for IR□200-A
- **Space savings** by not needing to install a mist separator between the air filter and the precision regulator.

### Flexible solution

#### Precision regulator - IR□000-A:

- Repeatability:  $\pm 0.5\%$  (full span)
- Sensitivity:  $\pm 0.2\%$  (full span)

#### Regulator - IR□200-A:

- Repeatability:  $\pm 1\%$  (full span)
- Selectable exhaust (EXH) direction - rear, bottom and front exhaust - for IR3□00-A
- Selectable direction of the knob, either upward or downward.



### Modular connection

Air filter      Regulator



Digital pressure switch  
- ISE30A series -  
available as standard

More information on the  
IR□000-A, IR□200-A series?



<http://IR.smc.eu/en>

# Accurate control for high pressure applications

## 3.0 MPa High Pressure Electric-Pneumatic Regulator **ITVH Series**

### Main benefits

- **Suitable for use in laser beam machines** – Where a high pressure control is needed for applications such as driving, sealing or proof pressure testing
- **Energy savings** – Due to less than 3 W power consumption
- **Space savings** – Due to its compactness, and lightweight.



### Application examples

Proof pressure test



Leak tester



Discharge rate control



More information on the ITVH series?



<http://ITVH.smc.eu/en>

# Simplify things

## Clean Exhaust Filter **SFE Series**

Main benefits

- **Cost and space reduction** – Because air can be directly exhausted in a clean room; there is no need for piping for exhaust and relief air
- **Cost reduction** – Due to installation of fewer elements as the same product includes a filter and a silencer
- **Mounting flexibility** – With its 3 different mounting variations.



3 mounting variations:  
 – One-touch fitting type  
 – Plug-in type  
 – Male thread type.

Bracket available

2 in 1: A Filter and a Silencer at the same time  
 High precision filtration  
 – Cleanliness class: 4. ISO 14644-1  
 – Filtration rating: 0.01 µm  
 – Filtration efficiency: 99.99 %  
 Includes silencer function  
 Noise reduction: 30 dB or more  
 Flow capacity: from 3 to 200 l/min.

Application examples

Design to be able to directly exhaust air inside a clean room

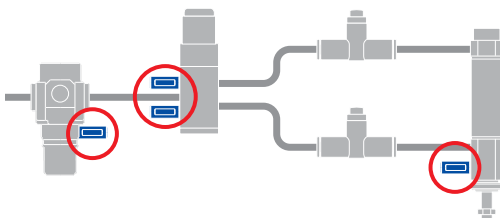

More information on the SFE series?



<http://SFE.smc.eu/en>

# Your filter regulator for corrosive environments

## Filter Regulator, Special Specifications **AW-X2622 Series**

### Main benefits

- **Suitable for corrosive environments** – According to NACE International Standards
- Appropriate for usage in **environments with a wide range of temperatures**
- **Correct operation with high inlet pressures.**

### Stainless steel 316 as external parts material

Body, bonnet and bowl

### NACE International Standards compliant

NACE provides standards for corrosion prevention and control used by a multitude of industries where corrosion is a key concern.

### Possibility to select both body size and port size

- AW30-X2622, with port sizes 1/4, 1/8
- AW40-X2622, with port sizes 1/4, 1/8, 1/2, 3/4.

### Stainless Steel 316 and Special Temperature Environment (-40 °C) Specifications

- Ambient and fluid temperature: -40 to 80 °C (no freezing)
- Set pressure range: 0.05 to 0.85 MPa
- Maximum operating pressure: 2 MPa.



More information on the AW series?



<http://AW-X2622.smc.eu/en>

# One move ahead on moisture control

## Moisture Control Tube **IDK Series**

### Main benefits

- **Ensure moisture control** – The new coil shape prevents the tube buckling when the actuator is moving
- **Prevent operation failure of your actuators** – Tube keeps condensation away from them
- **Save on labour and time** – Quick insertion and removal with one-touch fitting
- **Lower your air & power consumption** – No need for purge air and power supply compared to solutions based on air dryers.

If small actuators are continuously operated at high frequency, condensation may be generated even with dehumidified air

With the IDK moisture control tube the generated water vapour is diffused to the outside before being condensed.

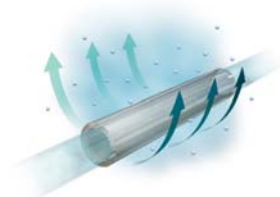

### More information on the IDK series?



<http://IDK.smc.eu/en>

### Various options available

- Linear/coil shape
- Length: 100 or 200 mm
- Tube: Ø 2, 4, 6 mm

### Application examples

Linear shape is suitable for applications where cylinders do not rotate



Coil shape is ideal for grippers or cylinders which make rotating motions. The rotating parts are met with flexible tubing

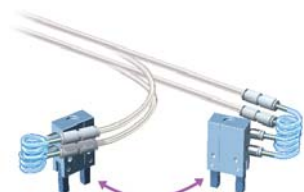

# Multiple lines, multiple colours, single easy identification

## Flat Tubing **TU, TUS & TUZ Series**

### Main benefits

- Users can **identify and manage the tubing by colours** thanks to its multi-colour specification
- **Cost and time saving** – As there is no need to bind it.



### Series TU: Polyurethane

- Tubing O.D.: Ø 2 to Ø 12 mm
- Tubing length: from 1 to 100 m
- Number of cores: 2 to 6 (Roll/Reel)
- 8 Colours: black, white, red, blue, yellow, green, clear and orange.

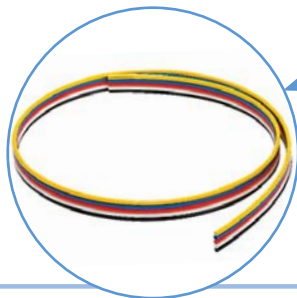

### Series TUS: Soft Polyurethane

- Tubing O.D.: Ø 4 to Ø 12 mm
- Tubing length: from 1 to 20 m
- Number of cores: 2 to 5 (Roll)
- 8 Colours: black, white, red, blue, yellow, green, translucent and yellow-brown.

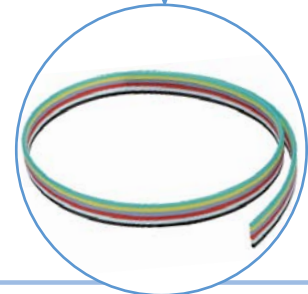
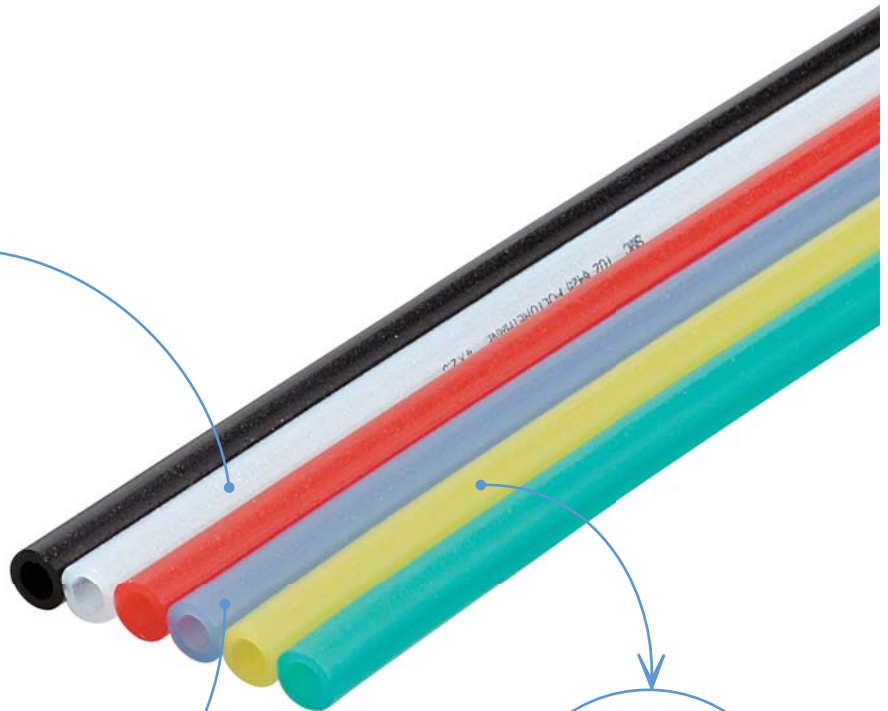

### Series TUZ: Wear resistant

- Tubing O.D.: Ø 4 to Ø 12 mm
- Tubing length: from 1 to 100 m
- Number of cores: 2 to 6 (Roll)
- 6 Colours: black, white, red, blue, yellow and green.

More information on the TU series?



<http://TU.smc.eu/en>

# Control the speed of your cylinder. Easier. Faster

## Speed Controller **AS/AS-FS Series**

Main benefits

- **Make assembly and maintenance easier** – Large 4-marked push-lock type handle that facilitates the adjustment and locking
- **Improve your process quality** – High adjustment reproducibility
- **Speed up the flow setting and control** – Numerical indication window in the AS-FS with 4 selectable orientations
- **Use it as a single unit or integrated in a manifold** – With the in-line type speed controller.

Large push-lock type knob

- It is scaled with four different marks every 90° for easy fine adjustment and set-up operation
- The needle can be locked/unlocked without requiring tools.



Numerical indication and control of the rotational number of the flow adjustment needle

- Possible to select the orientation of the indicator window
- The inclined position provides a wide viewing angle.



Wide range of models available in a wide variety of tubing sizes (from Ø 2 to Ø 16) and port sizes (from M5 to 1/2)

- Inch / metric sizes selectable
- Uni-thread type available
- Standardisation of electroless nickel plating type, stainless steel type and G thread (face seal) type.

**New**

4 mounting variations (in-line type)

- Direct mounting
- Holder mounting
- L-bracket mounting
- DIN rail mounting.



More information on the AS-FS series?



<http://AS-FS.smc.eu/en>



# Control speed in welding applications

## Metallic Speed Controller with One-touch Fitting **AS-X737 Series**

### Main benefits

- **Cost savings and long life** – As a result of its high environmental resistance thanks to its metallic exterior
- **Prevention of adhesion and entry of welding spatters** – When using the spatter cover
- **Maintenance savings** – As good visibility is guaranteed with the transparent spatter cover.

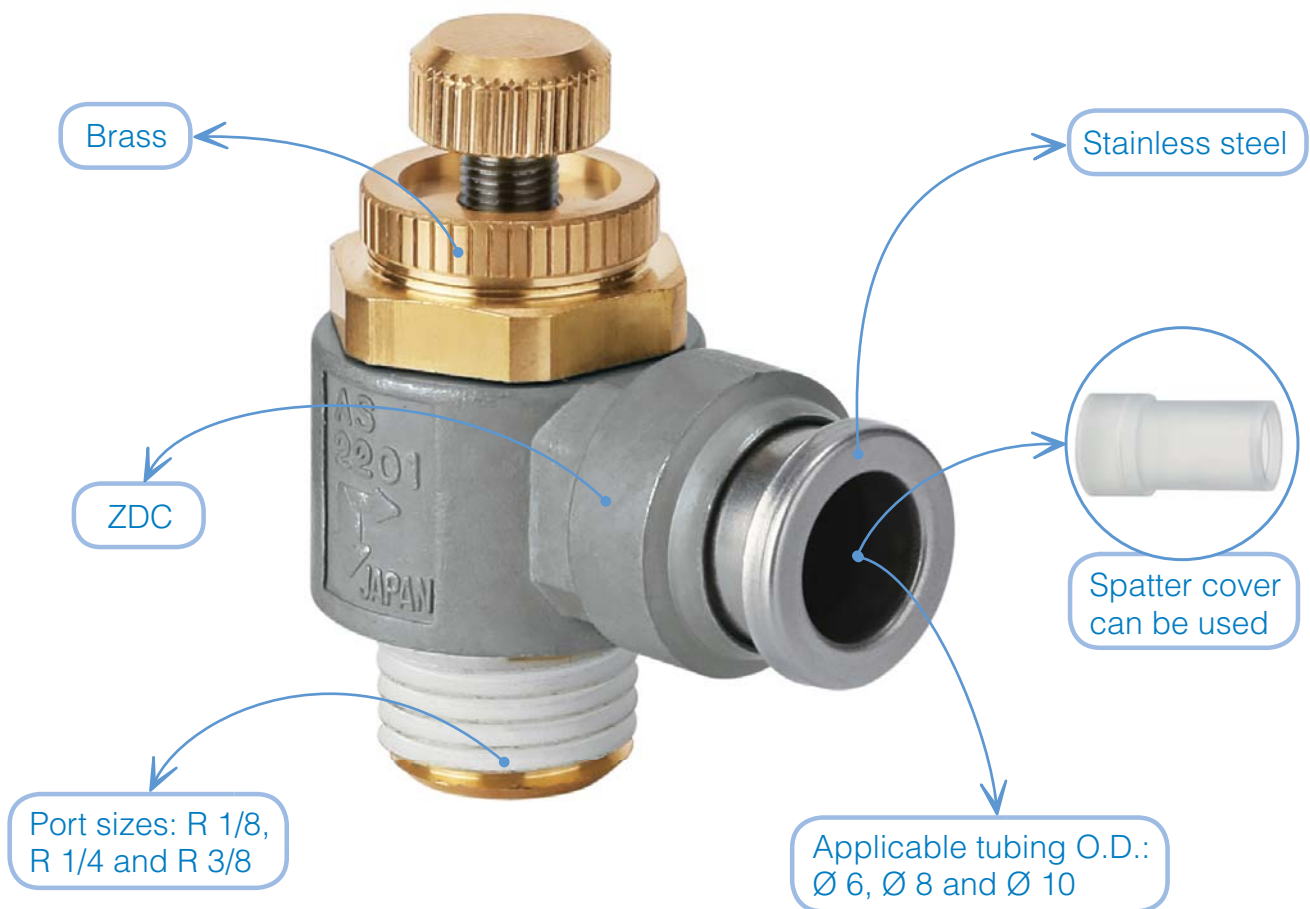

### Application examples

Where welding spatter is scattered

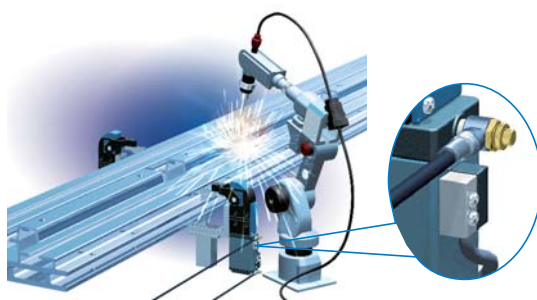

More information on the AS-X737 series?



<http://AS-X737.smc.eu/en>

# OEE or, if you prefer, the road to perfect production

Nowadays, it seems that one of the most popular methods for enhancing productivity is based on dealing with losses, and the vehicle used to do so is OEE.

This “new” buzz word actually entered manufacturing history for the first time in the late 60s. Overall Equipment Effectiveness (OEE) was coined by Seiichi Nakajima at Nippon Denso. OEE served as a key metric in TPM (Total Productive Maintenance). TPM was described by Nakajima as “a plant improvement methodology, which enables continuous and rapid improvement of the manufacturing process through the use of employee involvement, employee empowerment and closed-loop measurement of results.”

In order to obtain them, it is necessary to consider three fundamental pillars:

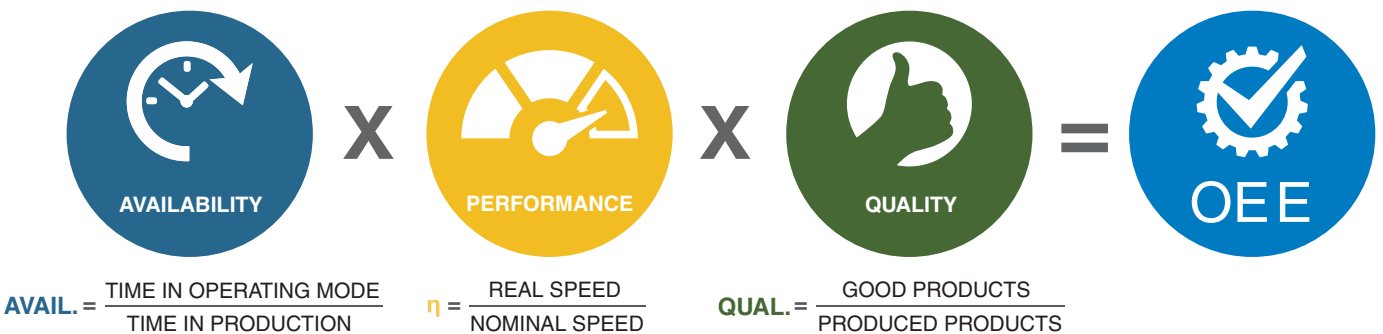

## The formula towards Perfect Production

OEE in really simple terms is: how close you are to perfect production - Manufacturing only good parts (Quality) as fast as possible (Performance), with no stoppage time (Availability).

The three ominous vowels, basically entail three concepts, Availability, Performance and Quality, which in turn lead us to the already famous 6 losses: Planned Downtime, Breakdowns, Idling or Minor Stoppages, Loss of Speed, Active Production Defects and Rejection Upon Start Up.

As with anything in life, being aware of the 6 big losses enables employees (a key part in any lean manufacturing implementation) to spot them and either eliminate or minimise them.

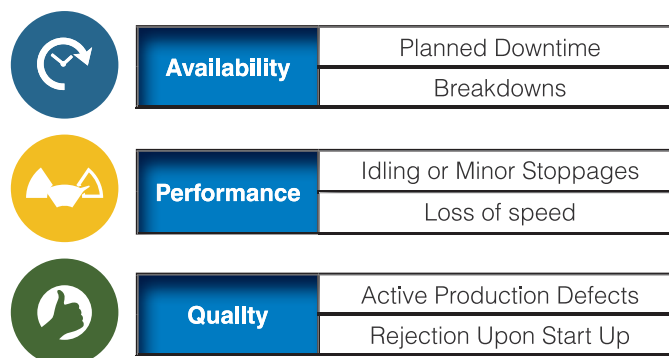

## What matters is the path, not the final destination itself

However, in this formula the final result, the OEE score is not the important part. Productivity enhancement outlays in focusing on the 6 losses. By tackling the Availability Loss, Performance Loss, and Quality Loss, the OEE will naturally improve, therefore bringing your factory closer to perfect production. An OEE of 90 % is not always better than one of 60 %. It depends. This KPI is encompassed in Lean Manufacturing, and Lean Manufacturing’s main mantra is: “Produce only what is needed, when it is needed and in the amount needed.” (Taiichi Ohno, Father of the Toyota Production System).

## Nevertheless, the goal is always bettering productivity, regardless of the acronym behind it

Each organisation has its own casuistry, but no matter which road, which acronym, which term we use, we all seek to improve our productivity. That is inherent to any production process. At the end of the day, OEE is just one of the production KPIs, there are others, there are many. KPIs tend, and should, vary by organisation. It is just a matter of finding the path that suits your needs and your company philosophy best.

### We talk “Productivity”

Given that good communication starts by talking the same language, we have learned how to talk “Productivity”.

We reckon it is not about individual automation components, but about their role in machine productivity or, in OEE terms, how they positively impact diminishing the 6 losses.

How the usage of an ionizer influences in avoiding unplanned maintenance, therefore hitting Minor Stoppages, and improving Performance. Or how the usage of a correct main line filter or water and mist separators to ensure the right air quality has a direct impact on practically all 6 losses, therefore bettering all three; Availability, Performance and Quality. The bottom line is that their usage moves perfect production forward.

In real terms, it does not really matter if you are implementing TPM, or OEE as a KPI; because in one way or another, you want to be as close as possible to perfect production. Productivity is a universal language that we are sure you talk.



# Fast static removal in your hands

## Fan Type Ionizer **IZF Series**

Main benefits

- **Remove static wherever you want** – 3 portable compact and light solutions. Ideal for those locations with no air supply
- **Reduce your consumption** – Rapid neutralisation in as little as 0.5 seconds
- **Operate it easily** – Multiple functions, features and alarms
- **Achieve efficient static electricity removal** to improve your productivity and to reduce downtime and costs.

Rapid static neutralisation with flow rate adjustment



Flow rate adjustment range:

- IZF10R: from 190 to 800 l/min
- IZF21: from 400 to 1800 l/min
- IZF31: from 1300 to 4400 l/min

Discharge time (at maximum flow rate):

- IZF10R: 1.3 s
- IZF21: 1.0 s
- IZF31: 0.5 s.

Emitter contamination level is constantly monitored



When maintenance is required, the user is alerted by a signal output and the LED turning on.



The Expert's opinion:

*We often see production issues caused by static; so we have intensified our efforts towards effective static removal with this portable, air-independent solution.*

MR. ALEJANDRO MOLINERO, PRODUCT MANAGER, SMC SPAIN.





### Extensive static neutralisation area can be covered with adjustable louvre

IZF 21 IZF 31

- Adjustable in 4-stages from wide to narrow angle
- 90-degree rotation mounting available (adjustable in a vertical direction).

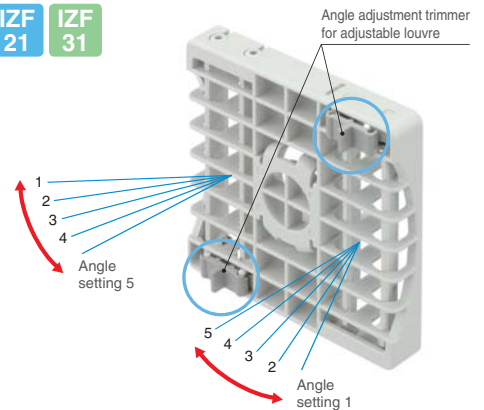

### Functions and features

IZF 21 IZF 31

- Emitter life is almost doubled with **averaging function**
- **Automatic balance adjustment function** that achieves stable offset voltage and reduces the adjustment time
- **Emitter cartridge** is easily replaceable (no tools required)
- **Automatic cleaning function** that cleans the emitter points with a brush by the motor driven rotating arms

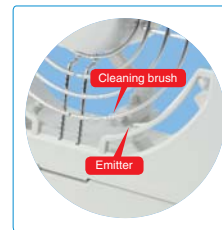

- **Optional filter** that prevents both the ingress of lint and foreign matter to the motor and the possibility of short-circuit between emitters.

### More information on the IZF series?



<http://IZF.smc.eu/en>

#### Application examples

Static neutralisation on a conveyor

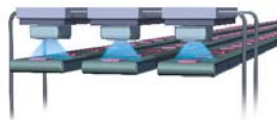

Neutralising static electricity on PET bottles

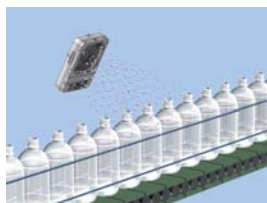

Neutralising static electricity from films

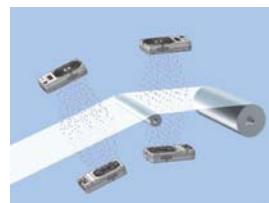

# Box up your dust and static issues

## Desktop Duster Box ZVB Series

Main benefits

- **Increase your efficiency** – Separated ion blow/air blow structure, plus the integration of 3 processes in one convenient place
- **Minimise maintenance** – Easy-to-remove, cleanable and replaceable emitter, plus maintenance-free pneumatic dust collector
- **Achieve operating comfort** – Automatic start-up after workpiece detection.

Emitter can be easily removed, replaced and cleaned



Static neutralisation

Diffusion-type nozzle that efficiently neutralises the static electricity in an extensive range of large workpieces.

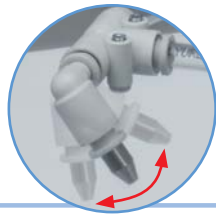

Dust removal

- Blow dedicated nozzles that ensure an efficient ion generation
- The angle and flow rate of the air blow can be adjusted (optional).

Dust collection

Maintenance-free pneumatic dust collector that gives a quick response in the dust suction while reducing the risk of malfunction.

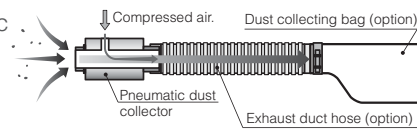

Optional photoelectric sensor reflecting plate

Automatically detects a workpiece and allows the immediate start of the operation.

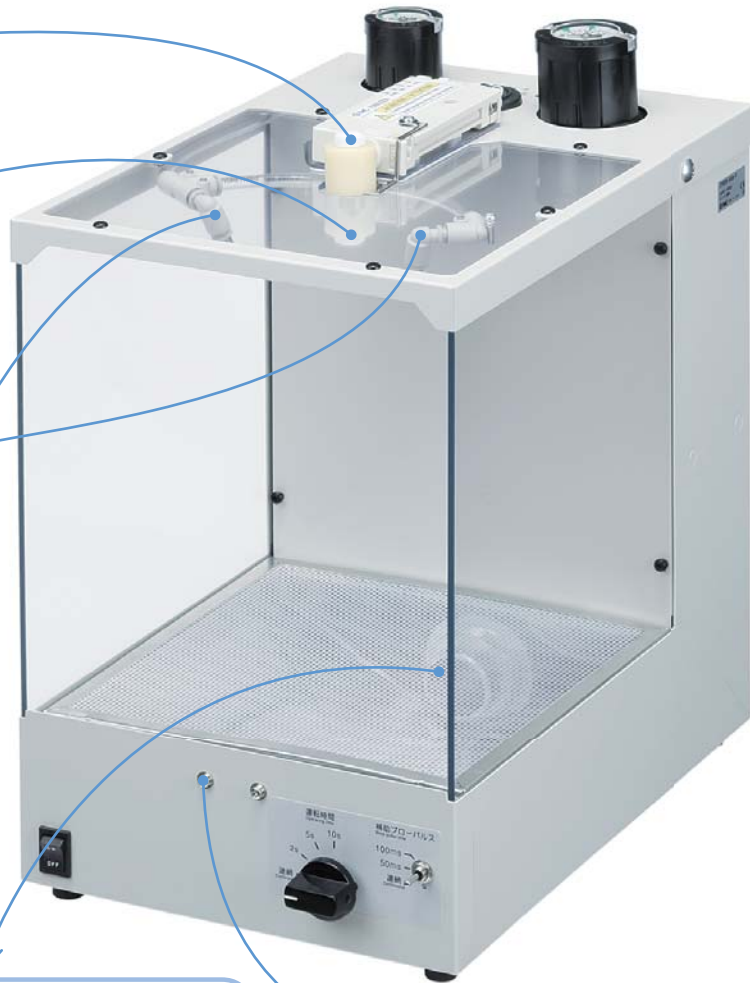

Application examples

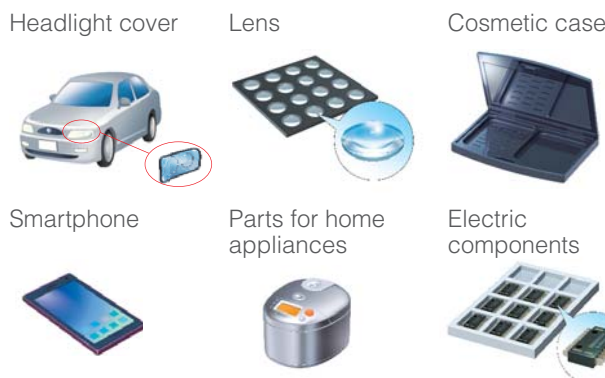

More information on the ZVB series?



<http://ZVB.smc.eu/en>

# Resistant visual monitoring solution

## 3-Colour Display Digital Flow Switch **PFMC Series**

### Main benefits

- **Guarantee yourself endurance in medium-harsh environment**
  - IP65 protection enclosure
- **Control the flow easily** – Set value and accumulated value can be clearly displayed at the same time
- **Ensure it will adapt to your required measurement needs**
  - Flow ratio 100:1
- **Place it wherever you need** – Compact design.



### More information on the PFMC series?



<http://PFMC.smc.eu/en>

### By-pass structure to improve the product life

Reduced contact of moist air and foreign matter with the sensor

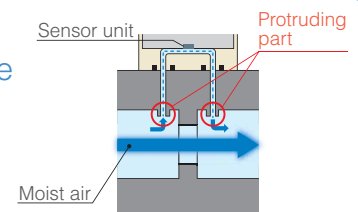

### Application examples

Remote flow control of main and branch lines

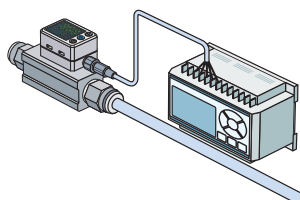

Control of the residual amount of N<sub>2</sub> in a gas cylinder

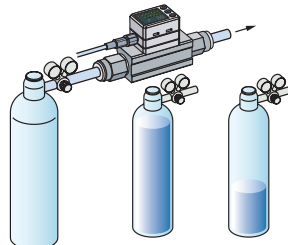

Flow control of the air for spray painting



# More & quicker information at your disposal

## High Precision Digital Pressure Switch **ZSE20(F)/ISE20 Series**

Main benefits

- **Get more information at a glance** – 2 specified items (measured & set value) can be displayed simultaneously
- **Achieve time savings with its easy setting** – 3 setting modes available
- **Detect possible failures quickly** – Delay time as little as 1.5 ms.

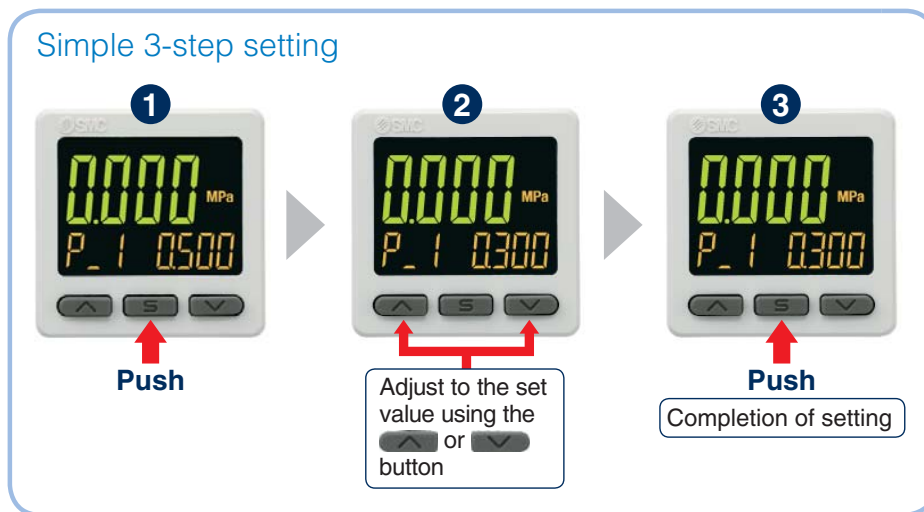
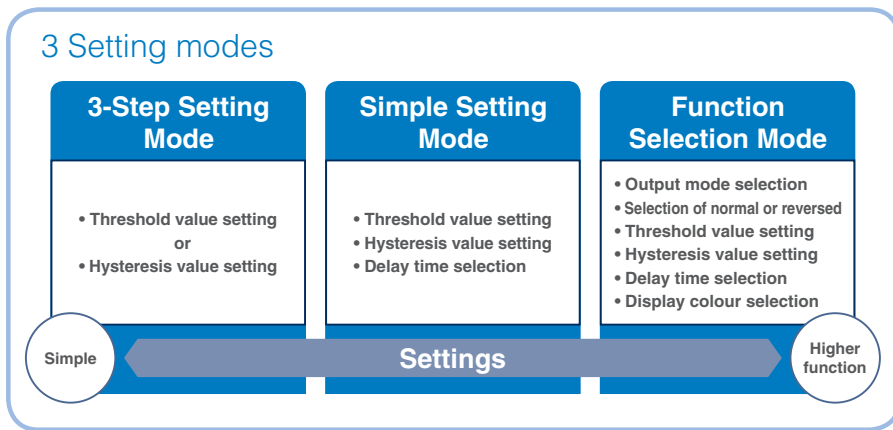

The Expert's opinion:

Most definitely one of a kind in its segment; not only does it offer a much quicker set-up, but our customers can also see both measured and set values at a glance.

MR. DIEGO SAIZ, SENIOR ENGINEER IN ELECTRICAL & INSTRUMENTATION SECTION, SMC EUROPEAN TECHNICAL CENTRE.





### 3-screen display

While checking the measured value, setting is possible  
Subscreen (label) shows the item to be set.

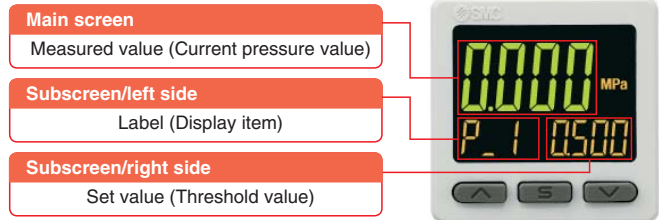

### Fast delay time

Fastest 1.5 ms or less, also 20, 500, 1000, 2000 or 5000 ms are selectable

### Records minimum and maximum value

It has a persistent memory which stores the value after switching off the sensor

### Compact & lightweight

### Digital filter

Reduces the display fluctuation during operation when unstable pressure is applied

### Low current consumption

25 mA or less.

More information on the ZSE20(F)/ISE20 series?



<http://ZSE20.smc.eu/en>

### Application examples

- Air pressure measurement
- Monitoring of N<sub>2</sub> pressure
- Checking of source pressure value and adsorption pressure in an adsorption process (pick & place)
- Checking the source pressure of an air line
- Confirmation of suction and seating on a transfer line.

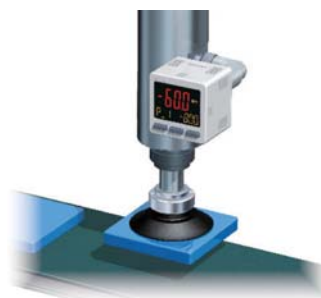

# Stands up to the pressure

## Pressure Sensor for General Fluids **PSE570 Series**

Main benefits

- **Get a long-lasting solution** – High resistance against excess pressure or abrupt surges
- **Have one sensor for all your needs** – Highly versatile product
- **Save time and money in wiring and piping** – M12 connector and remote monitoring.

High resistance to pressure, voltage surges and harsh environments

- High proof pressure: up to 3 times higher than the rated pressure
- High withstand voltage between body parts and electronic circuits: 500 V AC
- IP65 enclosure protection.

M12 connector

Can be used to connect to analogue input units  
**Separate sensor and display**  
 Accurate and remote control of the pressure.

Good for measuring a wide range of fluids  
 Great product variety

- **6 selectable rated pressure ranges:** from compound pressure (-100 to 100 kPa) up to high positive pressure (maximum 10 MPa)
- **Selectable output specifications:** 1 to 5 V voltage output, 4 to 20 mA current output.

More information on the PSE570 series?



<http://PSE570.smc.eu/en>

Application examples

Liquid coolant pressure control

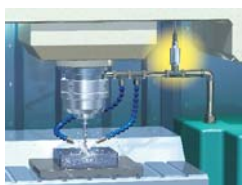

PET bottle moulding machines



Discharge pressure control of compressor



Liquid pressure control of gun drills

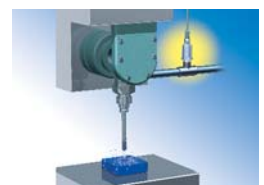

# Set & Go

## Digital Gap Checker **ISA3 Series**

### Main benefits

- **Set it up easily** – In just 3 steps
- **Reduce inspection time** – Workpiece seat conditions can be checked at a glance
- **Save money & labour time** – Considerable reduction in energy consumption and installation time with the centralised wire
- **Use it in quiet environments** – Zero exhaust air noise.

### Two screens enable various information to be checked:

- Check at a glance if the workpiece is placed or not!
- The subscreen display can be selected from 6 display options.



### Easy setting by the digital display: 3-step setting

**STEP 1**  
Press



**STEP 3**  
Press to complete

**STEP 2**  
Set the switch point value

Level meter

Switch point value bar



**New**

### Centralised lead wire



Wiring can be performed without tools with the M12 connector



### Easy maintenance

The internal orifice part can be removed for cleaning.

Detection principle without exhaust air

### Application examples

Confirmation of the datum level for press fitting of a shaft

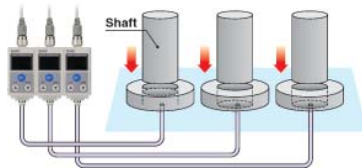

Confirmation of close contact with the workpiece or the datum level for machining

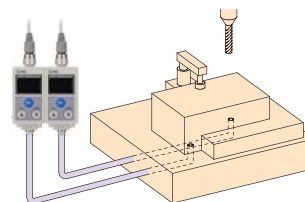

More information on the ISA3 series?



<http://ISA3.smc.eu/en>

# Control your CQ2 in high temperature applications

## Heat Resistant Solid State Auto Switch for CDQ2 **D-M9J Series**

Main benefits

- **Detect the position** of your CQ2 **compact cylinder** at **high temperature** – Up to 150 °C
- **Set & Adjust it easily** – 2-colour indicator
- **Mount effortlessly** – Round groove mountable auto switch.

Two output types available

- PNP
- NPN

Heat resistant

- The sensor part can be used up to 150 °C (the amplifier can be used from 0 to 60 °C).



Round groove mountable auto switch

IP67 for sensor unit (Amplifier unit: IP63)

More information on the D-M9J series?



<http://D-M9J.smc.eu/en>

# Forget all about mounting brackets

## Trimmer Auto Switch Sensor Unit **D-M9K Series**

### Main benefits

- **Sensor unit mounting labour reduced** – Due to the fact that round sensor units can be mounted directly in the actuators
- **Flexibility** – As the cable length can be decided by the customer and various sized workpieces can be detected with only one switch
- **Cost reduction** – Because if the sensor or amplifier is broken, the customer will only need to replace the broken part.

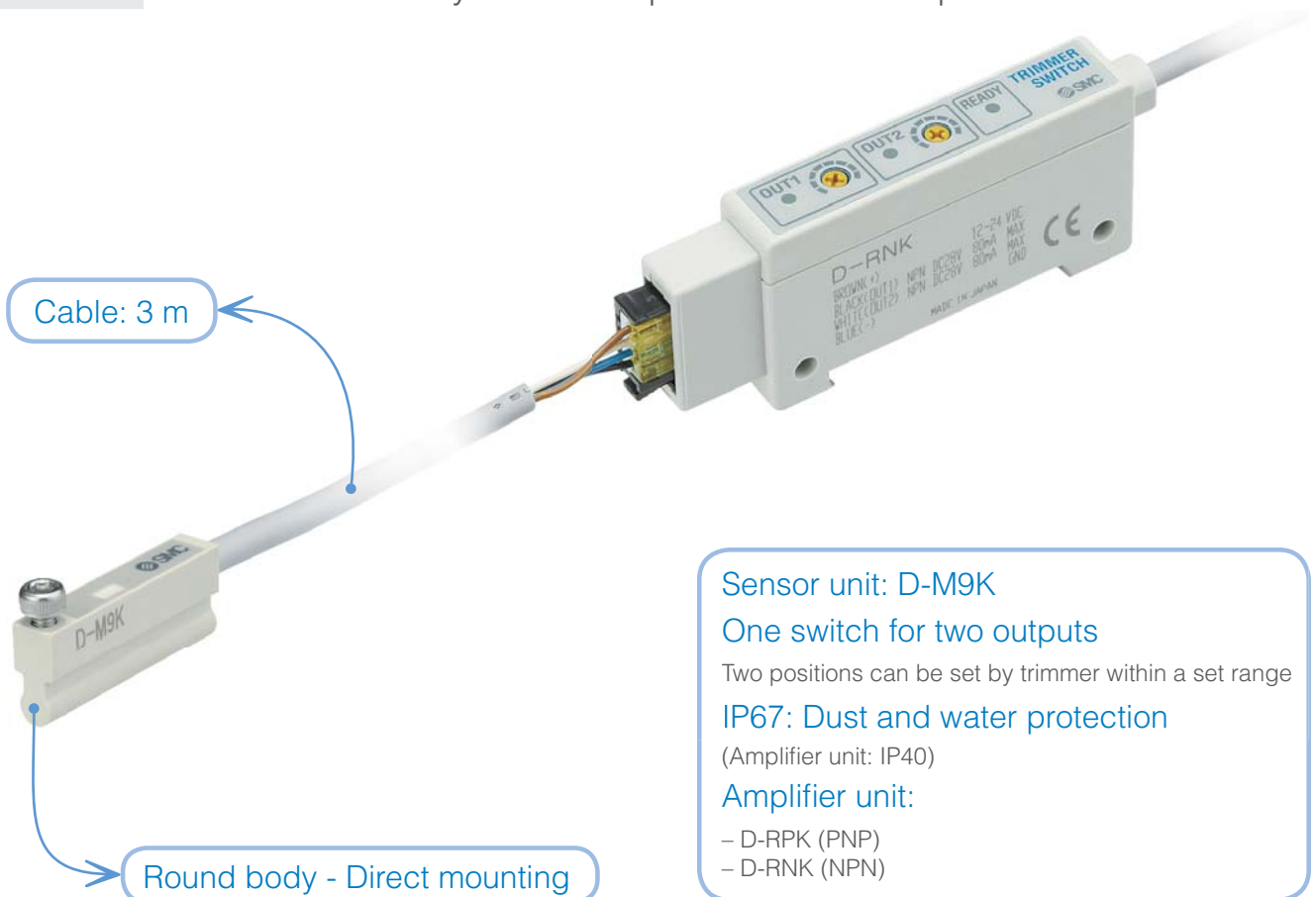

Sensor unit: D-M9K

One switch for two outputs

Two positions can be set by trimmer within a set range

IP67: Dust and water protection

(Amplifier unit: IP40)

Amplifier unit:

- D-RPK (PNP)
- D-RNK (NPN)

### Application examples

For checking height of a workpiece

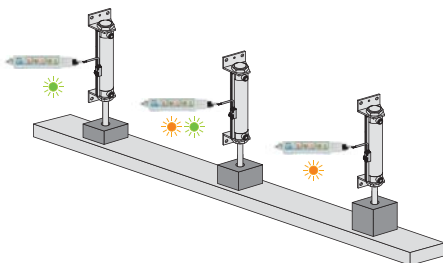

For checking depth of the machined hole

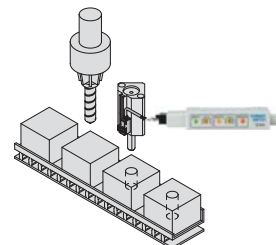

More information on the D-M9K series?



<http://D-M9K.smc.eu/en>

# Improve the performance & reliability of your machine

## Thermo-Chiller, Compact Type **HRS Series**

Main benefits

- **Optimise the quality of your process** – Great temperature stability
- **Get that smart solution that will give you proactive control**
  - Remote control to manage any anomalies or incidents
- **Get worldwide support**
- **Keep yourself informed** – Advanced control functions.



**New**

**IPX4 protection**

Possibility of outdoor installation (HRS100/150 Series)

**Large digital display**

- Convenient functions
- Self-diagnosis function and check display
- Communication function.

**Heating function available even with no heater**

Temperature stability even in winter

**Front and back ventilation**

Possible to install close to a wall on both sides.



**HRS100/150** **New**

Air/water-cooled  
Cooling capacity: 10/15 kW  
Temperature range: 5 to 35 °C  
Temperature stability: ±1 °C

**HRS**

Air/water-cooled  
Cooling capacity: 1.1 to 4.7 kW  
Temperature range: 5 to 40 °C  
Temperature stability: ±0.1 °C

**HRS090** **New**

Air/water-cooled  
Cooling capacity: 9 kW  
Temperature range: 5 to 35 °C  
Temperature stability: ±0.5 °C

Application examples

X-ray (digital) instrument.  
Temperature control of X-ray tube and X-ray light sensing part

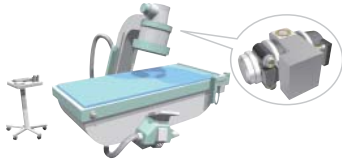

Laser marker.  
Cooling of laser irradiated part

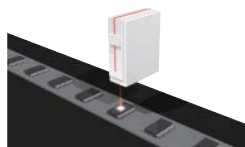

UV curing device (printing, painting, bonding and sealing)  
Cooling of UV lamp

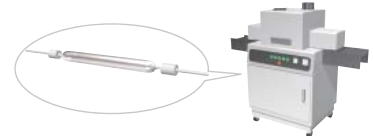

More information on the HRS series?



<http://HRS.smc.eu/en>

# Cool down your costs

## Thermo-chiller. Basic type **HRSE Series**

### Main benefits

- **Reduce your costs** – Low power consumption
- **Keep yourself informed** – Self-diagnosis function
- **Operate it easily** – 2-step simple operation
- **Simplify your maintenance** – Fluid fill port and circulating fluid window placed on the front.

### Low power consumption



### Self-diagnosis and check display

- 12 alarms: Several types of alarm codes and conditions can be displayed
- 2-step simple operation: Digital display panel with information and buttons.

### Simplified maintenance

- Fluid fill port and circulating fluid window placed on the front
- No tools required to mount/remove the front panel.

Cooling capacity: 1 kW to 1.9 kW  
Set temperature range: 10 to 30 °C  
Temperature stability:  $\pm 2.0$  °C  
Low noise level: 57 dB

### Application examples

Arc welding machine



Printing machine

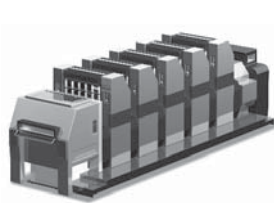

Electronic microscope



More information on the HRSE series?



<http://HRSE.smc.eu/en>

# Triple savings at the right temperature

## Thermo-Chiller **HRSH Series**

### Main benefits

- **Cost savings with energy savings**
- **Reduced labour time** – With easy operation and control, and reduced maintenance work
- **Space savings** – With overall machine size kept to a minimum.
- **Temperature stability** – Even in winter
- **Increased productivity and maximum machine performance** – With optimisation of process quality.

### Improved maintenance performance with advance control functions that provide optimum reliability

- Large self-diagnosis and check digital display
- Front access to electrical components (not for HRSH090)
- Optional fluid fill port for the circulating fluid (not for HRSH090)
- Easy check of the circulating fluid (only HRSH090)
- Tool-less inspection and cleaning of air-cooled condenser.



### Reduced power consumption with a triple inverter

- The triple inverter individually controls the compressor motor, the fan and the pump, thus optimising control of the number of motor rotations depending on the load

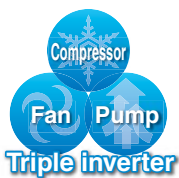

1. DC inverter compressor
2. DC inverter fan
3. Inverter pump

- The inverter pump has a power reducing effect since there is no need for different piping conditions, for any bypass valve for adjustments.



### The Expert's opinion:

*Our drive for energy efficiency for the benefit of the environment and the competitiveness of our customers have driven us to develop our latest thermo-chiller with reduced power consumption.*

MR. ADRIAN DICA, GROUP LEADER IN "VALVES AND AIR EQUIPMENT SECTION", SMC EUROPEAN TECHNICAL CENTRE.





## Use of a mechanical seal-less immersion pump

No need to check the pump leakages periodically or to replace the seal (not for HRSH090)

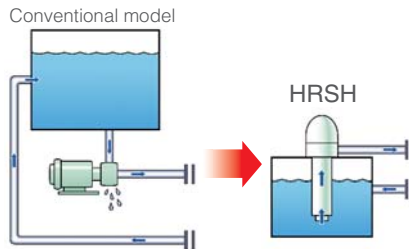

## Heating function available even with no heater

- Circulating fluid can be heated by using the exhaust heat (hot gas) from the compressor circuit
- Temperature stability even in winter

## Compact and lightweight

It uses an integrated pump, a small tank, and an aluminium air-cooled condenser

**Cooling capacity:** from 9.5 to 25 KW

**Cooling methods:** Air/water-cooled

**Temperature range:** 5 to 35 °C

**Temperature stability:**  $\pm 0.1$  °C.

## Application examples

### Laser beam machine/laser welding machine

Cooling of the laser oscillation part and power source

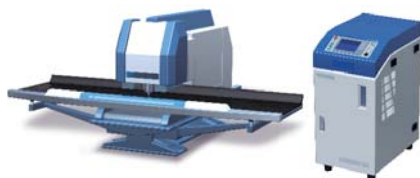

### Arc welding machine

Cooling of the power source



### High frequency induction heating equipment

Cooling of the heating coils, high frequency power source and around inverters



More information on the HRSH series?



<http://HRSH.smc.eu/en>

# Great temperature stability for standard mounting

## Peltier-Type Chiller, Thermo-con/Rack Mount Type **HECR Series**

Main benefits

- **Obtain a quieter working environment** – Its design with fewer moving parts makes it less prone to vibrate
- **Save space and installation time** – Mount multiple equipment units together in a rack
- **Increase your productivity and maximise your machine performance** – Great temperature stability.

Fluid fill port and circulating fluid window placed in the front



Self-diagnosis and check display

- 14 alarms: Several types of alarm codes and conditions can be displayed
- 3-step simple operation: Digital display panel with information and buttons.

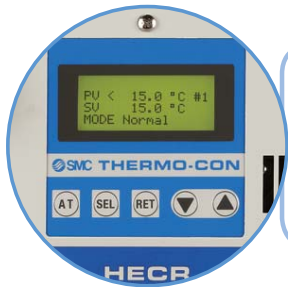

Application examples

**Laser machining**

Cooling of laser irradiated part



**UV curing device (printing, painting, bonding and sealing)**

Cooling of UV lamp



**X-ray (digital) instrument**

Temperature control of X-ray tube and X-ray light sensing part

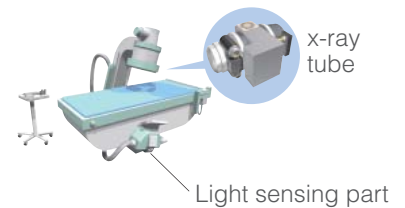

The Expert's opinion:

*We reckon standard not only means average but also product compliance coupled with standout features to give our customers that extra that is "nice-to-have".*

MR. ROBERTO MARTÍNEZ DE LAFUENTE, HEAT EXCHANGERS PRODUCT MANAGER, SMC SPAIN.

### Mountable in a 19-inch rack

It can be mounted together with multiple equipment in a rack



### Low-noise and vibration design

- Between 49 and 54 dB
- Structure without compressor makes it less prone to vibrate
- When the cooling load is low the fan rotations decrease
- HECR is ideal for precision equipment working-rooms.

Excellent temperature stability:  $\pm 0.01$  to  $0.03$  °C

Set temperature range: 10 to 60 °C

Circulating fluid: Tap water, ethylene glycol 20 %

Cooling capacity / heating capacity:

HECR002 (200 W / 600 W)

**New** HECR004 (400 W / 1 kW)

**New** HECR006 (510 W / 1.2 kW)

**New** HECR008 (800 W / 1.4 kW)

HECR010 (1 kW / 2 kW)

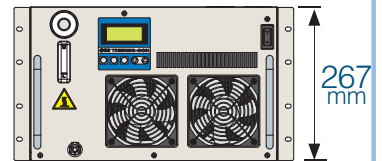

### Learning control function:

Temperature control by external temperature sensor.

### Application examples

#### Electronic microscope

Temperature control of electron-beam irradiated part



#### Laser marker

Cooling of laser irradiated part

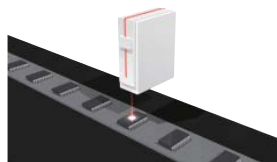

#### Ultrasonic wave inspection machine

Temperature control of ultrasonic wave laser part



More information on the HECR series?



<http://HECR.smc.eu/en>

# Temperature stability that guarantees process quality

## Peltier-Type Thermoelectric Bath **INR-244 Series**

### Main benefits

- **Easy operation and control** – With reduced maintenance due to the lack of refrigerant
- Can be used in quiet environments
- Useful for applications where a big bath is necessary
- **Space savings** – Suitable for use in reduced spaces.

### Liquid bath

Square type with capacities up to 39 L



### Control functions

- Alarms (high/low temperature, stop, controller, etc.)
- Offset function
- Serial communication function via RS-232C or RS-485.

### Peltier element

Low vibration and high accuracy

**Cooling capacity:** 140 to 320 W

**Heating capacity:** 300 to 700 W

**Temperature stability:**  $\pm 0.03$  °C

**Temperature range:** 0 to 60 °C

**Cooling methods:** Air/water-cooled

### Temperature sensor

Direct measurement of liquid temperature, with excellent display accuracy

### Built-in circulating pump

The agitation by the built-in circulating pump reduces the temperature distribution inside the bath.

### Application examples

Temperature control of source gas for MO-CVD or diffusion furnace



Temperature control of sample and reagent



Conductivity meter



More information on the INR-244 series?



<http://INR-244.smc.eu/en>

# Absolutely trustworthy

## 2/3 Port Media Separated Valve **LVMK20/200 Series**

### Main benefits

- **Trust its reliability** – Block seal prevents armature sticking and corrosion
- **Be sure to prevent fluid pollution** – Block seal stops fluid entering the solenoid assembly
- **Clean it easily** – Minimal dead space
- **Simplify the piping** – Integrated barb fitting.

Media/Fluid Separation Structure  
Low Particle Generation  
Oil and Metal Free

Two models:

- Base mounted
- Body ported.

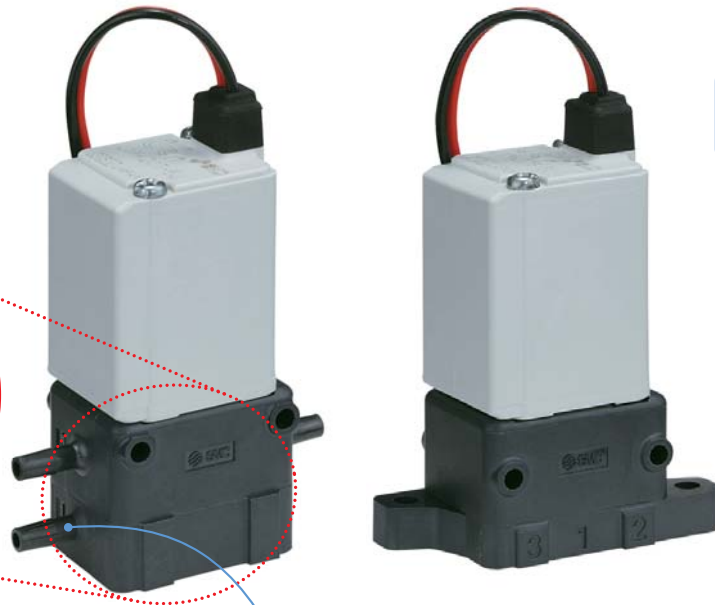
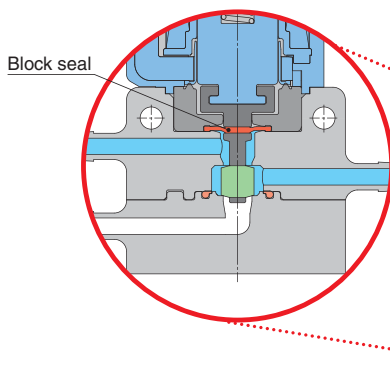

Flow rate adjustment not required for 3 port valve

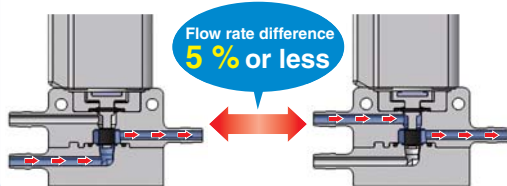

Integrated Barb Fitting

Minimal dead space

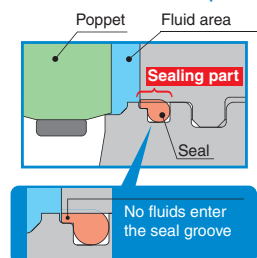

### Application examples

Blood analyser



Ink dispenser



Pure water purification equipment



More information on the LVMK20/200 series?



<http://LVMK.smc.eu/en>

# Highly solvent

High purity valve for organic solvents,  
air or manually operated **LVA/LVH Series**

## Main benefits

- **Get a solid solution to convey organic solvents**
- **Fit it easily in your process** – 3 different types of fittings available
- **Clean it perfectly** – Body wetted parts equivalent to EP grade
- **Ensure long life for your upstream components** – Low water hammer type (LVA Series).

Compatible with organic solvents

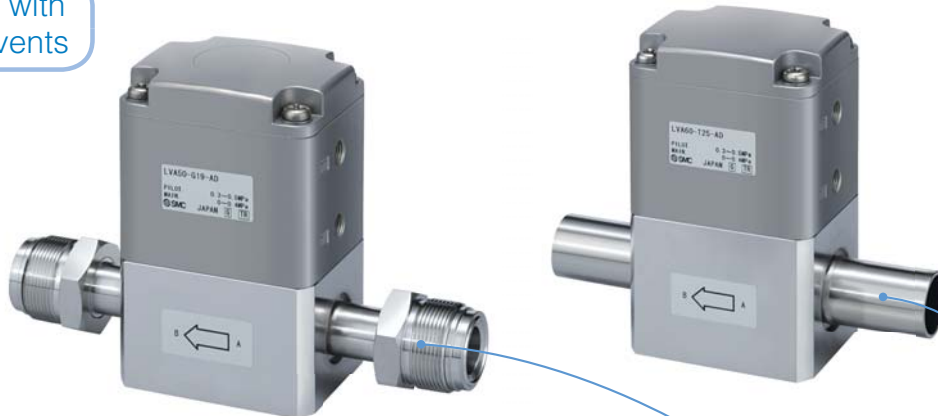

## Valve materials:

- Body: Stainless steel
- Actuator section: ADC (Aluminium die casting)
- Buffer: FKM or EPDM.

## 3 Fittings type:

- Double ferrule fittings
- Metal gasket seal fittings
- Integrated tubing.



## Options available:

- Body wetted parts equivalent to EP grade
- Low water hammer type (LVA series)
- High back pressure (0.5 MPa) tolerant (LVA series)
- With flow rate adjustment (LVA series)
- With indicator (LVA series).

More information on the LVA/LVH series?



<http://LVA-LVH.smc.eu/en>

# Withstands high temperature

## 2 Port Solenoid Valve / Air Operated Valve for Dust Collector **VXF Series**

### Main benefits

- **Achieve a quick discharge of the bag filter** – High discharge flow rate, big orifice sizes and high speed response (double diaphragm structure)
- **Lower your compressor power consumption** – Capable of cleaning the bag filter with low pressures
- **Benefit from wider range of operating pressures.**

### Piping variations

Direct Piping Type

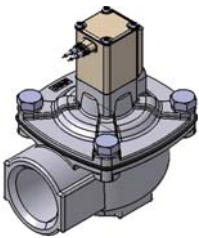

Flange Type



Flange Body I Type

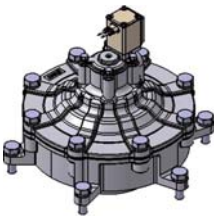

Flange Body II Type

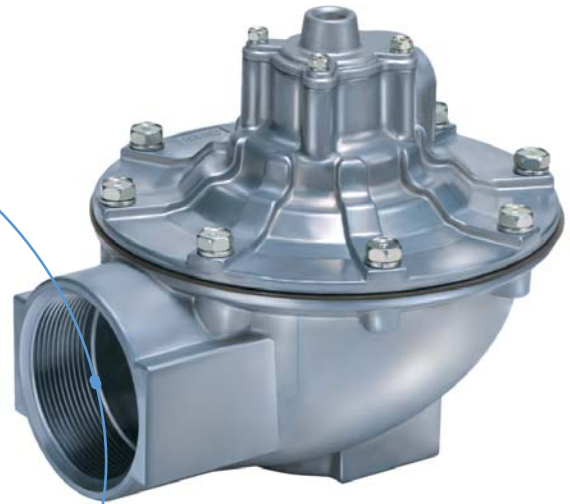
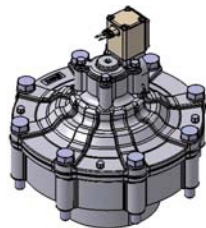

Large port size available:

From G 3/4 to G 4

### Dedicated Controller: Series VXFC



Applicable for high temperature fluids, 100 °C, due to the FKM/ PTFE diaphragm and main valve material

Large orifice sizes:

From Ø 22 to 100 mm

High discharge flow rate:

Up to more than 1000 L

Power consumption:

4.5 W (Size 21, 22, 24, 25, 26, 27, 28), 8 W (Size 23)

Low noise construction

Impact noise reduced by the rubber buffer

Improved armature durability

Flame resistant UL94V-O conformed IP65 degree of protection.

Electrical entry "Faston" type terminal is IP40.

More information on the VXF series?



<http://VXF.smc.eu/en>

# It will live up to your expectations

## Angle Seat Valve for Steam, Air and Heated Water **VXB Series**

### Main benefits

- **Cost reduction** – Because of its long service life
- **Reduced maintenance cost** – Thanks to the strong construction and to reducing the entry of foreign objects
- **Reliability improved** – With its high sealing and minimal leakage.

### Body material

Bronze, Stainless  
Steel 316L equivalent



### Port size:

3/8, 1/2, 3/4



### Long service life:

**Air:** 5 million cycles

**Steam:** 3 million cycles

### High sealing, minimal leakage:

Minimal internal air leakage: **10 cm<sup>3</sup>/min or less**

(Significantly better tightness than any PTFE sealed valve)

High sealing thanks to a rubber seal made of a **special FKM**

### Insulated adapter type

Available for high temperature fluids.

### Application examples

Steam cookers



Sterilizers for food containers



Boilers



### The Expert's opinion:

*An angle valve needs to be robust, unalterable by contaminants. That is the idea behind VXB; you can expect the same performance throughout its million cycles.*

MR. PHILIPPE LE PROVOST, SPECIALIST PRODUCT INSTRUMENTATION & FLUID CONTROL, SMC FRANCE.



**New**

With indicator

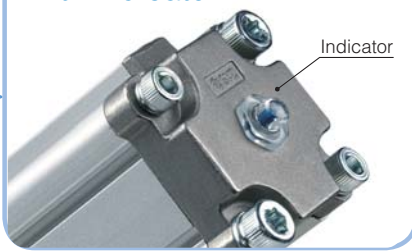

Pilot port location

Can be placed in 3 of its 4 sides



Special construction:

A **protective seal** prevents foreign particles from getting inside when the valve is open

A **resin scraper** functions during the main valve stroke as a guide and prevents foreign particles from getting in

**Squeeze seal** with scraper function added to shut off fluid leakage

A **guide bushing** gives smooth shaft movement, prevents misalignment and lengthens the squeeze seal life.

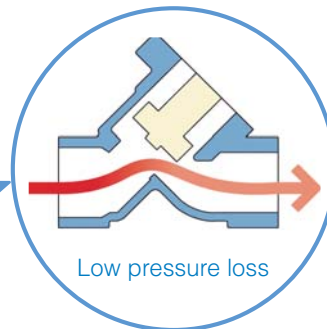
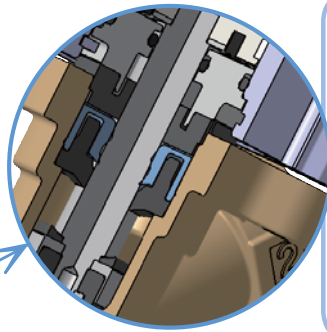

Application examples

Sterilisation of filters in a filling machine for milk



Industrial laundry machines



Sterilizers for medical equipment



More information on the VXB series?



<http://VXB.smc.eu/en>

# Improve the performance of your sorting application

## High Speed 2 Port Valve **SX10 Series**

### Main benefits

- **Sorting performance improved** – Due to the high speed response times
- **Production increased** – Thanks to the high frequency rates
- **Cost reduction** – Because of its long service life and its energy saving type with low power consumption.

### High speed response times:

ON at 0.45 ms

OFF at 0.4 ms

### High frequency rates:

Up to 1200 Hz

### Long service life:

More than 5000 million cycles

### Energy saving type

With low power consumption available: 4 W

### Filter attached type available



More information on the SX10 series?



<http://SX10.smc.eu/en>



### The Expert's opinion:

*The determining factors in high speed applications such as optical sorting of beans, rice, glass, plastics, pills etc., are footprint and switching times. The SX10 is one of the smallest and fastest valves on the market.*

MR. SCOTT PRITCHARD, BUSINESS DEVELOPMENT MANAGER - LIFE SCIENCE AND SCIENTIFIC PRODUCTS, SMC PNEUMATICS (UK) LTD.



**Slim dimensions:**

The width of both types is 9 mm

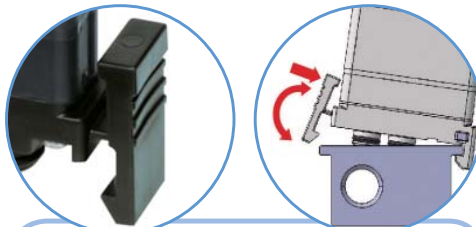

**Easy installation and removal**

In the quick disconnect type.

**2 Mounting types available**



Quick disconnect type



Screw mount type

**Application examples**

Colour sorting: Grains (rice, soya beans...), tablets, pellets, rubbish for recycling...



Pulse blower: Blowing off foreign objects, cleaning solutions, etc.

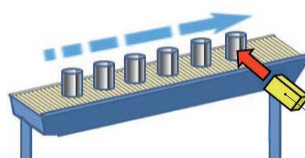

High speed 2 port valve

# Reduce your costs in steam applications

Pilot Operated 2 Port Solenoid Valve / Zero Differential Pressure Type **VXS Series**

**Main benefits**

- **Cost reduction** – Because of its long service life and its reduced power consumption
- **Reduced maintenance cost** – Thanks to the strong construction and to reducing the entry of foreign objects
- **Applicable with low pressure fluids** – Due to the zero differential pressure construction.

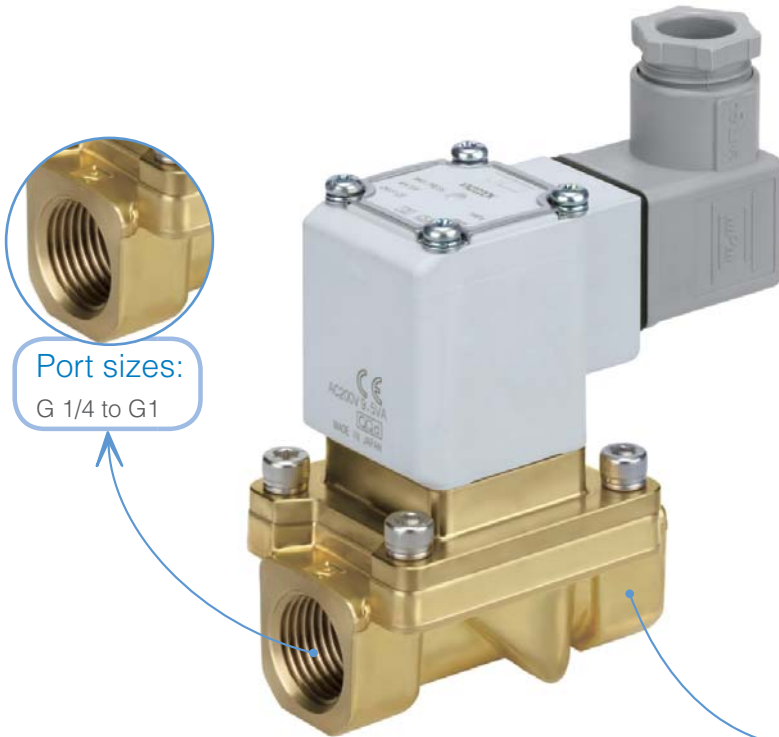

Can be used with heated water

**Steam**

Port sizes:  
G 1/4 to G1

Long service life: 3 million cycles  
Minimum operating pressure differential: 0 MPa  
No fluid pressure required for the valve operation.

**Body material**  
Brass, stainless steel.

**Power consumption**  
12 VA (VXS23/24)  
15 VA (VXS25/26)

**Double guide rings:**

- Stable sliding performance
- Improved scraper performance reduces the entry of foreign objects

**High sealing, minimal leakage:**

- Minimal internal air leakage: 1.0 cm<sup>3</sup>/min or less (Significantly better tightness than any PTFE sealed valve)
- High sealing with a piston main valve and a rubber seal made of special FKM.

Flame resistance UL94V-0 conformed  
IP65 degree of protection  
**Low noise construction**  
Impact noise reduced by the rubber buffer  
**Improved armature durability**

More information on the VXS series?



<http://VXS.smc.eu/en>

# Inclusive solution for trouble-free vacuum

## Vacuum Filter **AFJ Series**

### Main benefits

- **Profit from an optimised solution in vacuum filtering** – Dust and water droplet removal in a single solution
- **Achieve minimum and easy maintenance** – Total visibility from any angle, plus no need for tools to replace the reusable filter elements
- **Extend the life of your vacuum adsorption systems** – High filtration rates
- **Get endurance and a long-life product** – Double layer bowl construction ensures good environmental resistance.

### Many options selectable:

- Filtration rating: 5, 40, 80 µm
- 3 body sizes
- 4 port sizes
- Bowl material
- Flow direction.

### Front access to the lock button

Minimum maintenance is required. The reusable filter elements replacement can be done with hand.



### Internal bowl

Transparent bowl guard provides total visibility from any angle.

### Large flow type

### Water drop removal type

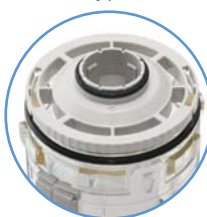

AFJ-T series

AFJ-S series

### Application examples

Preventing cleaning water left on the workpiece from entering into the ejector when a pad picks up the workpiece

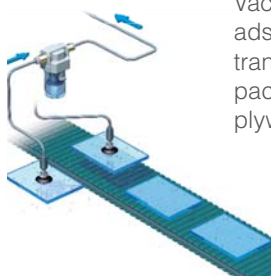

Vacuum line adsorption pad to transfer cardboard packaging box or plywood

### More information on the AFJ series?



<http://AFJ.smc.eu/en>

# Ease your vacuum generation

## Vacuum Pad with Ejector **ZHP Series**

**Main benefits**

- **Cut your costs** – Easy design that integrates a vacuum pad with an efficient ejector in a compact single unit
- **Simplify the mounting and reduce your maintenance** – Simple removal and mounting; perfect to fit in confined spaces
- **Improve your work environment** – Reduced contamination and noise.

**Through-hole silencer in the release**

The exhaust is discharged directly to the atmosphere, which reduces the noise and minimises the clogging.

**3 port locations**

Great usability possible thanks to daisy-chain

“Slave” function - possible serial connection without ejector

Daisy-chain vacuum piping example



Strainer that prevents foreign matter from entering



**The Expert's opinion:**

*ZHP is a very compact and practical solution; our customers welcome the flexibility it brings in the design of their vacuum systems.*

MR. PATRICK BOERDIJK, MARKETING, SMC NETHERLANDS.

Lock-plate structure that enables easily attaching and detaching the pads



Shot-blasted pad with grooves that eases the workpiece removal

- Pad diameters: Ø 63, Ø 80
- Pad forms: Bellows type with groove, flat type with groove
- Pad materials: NBR, silicone rubber, urethane rubber, FKM.

Two-stage ejector

Improved vacuum generating efficiency: flow rate increased by 50%, air consumption reduced by 30%  
Nozzle sizes [mm]: Ø 0.7, Ø 1.0, Ø 1.2, Ø 1.5.

More information on the ZHP series?



<http://ZHP.smc.eu/en>

Application examples

Car



Case packer



Robot handling  
Palletising

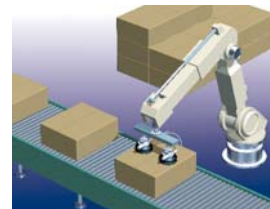

# Strong retention, Smooth liberation

## Vacuum Pad With Grooves ZP3E Series

Main benefits

- **Handle with reliability** – The machined grooves in the surface prevent removal failures and improve adsorption force
- **Accomplish suction position stability** – Its ribs reduce the inclination during workpiece transport
- **Reduce your labour time and costs** – Easy mounting of the pads
- **Save space** – Direct mounting option.

Stability of suction position

- Dents and bumps on the adsorption surface expand the area which is in contact with the workpiece
- Ribs reduce the inclinations during transport of workpiece.

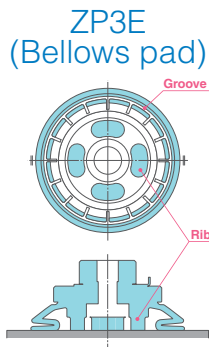

The metal parts and rubber parts can be separated completely for recycling



Suction flow rate increased

Applicable to workpieces with a large suction flow rate and high permeability.

Mark-free NBR pad available

For use where adsorption marks must not be left on workpieces

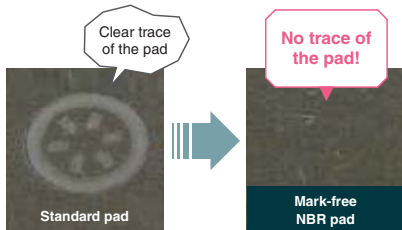

Number of mounting screws reduced

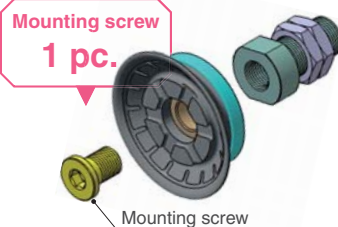

More information on the ZP3E series?



<http://ZP3E.smc.eu/en>



# The solution for gentle transport

## Non-Contact Gripper XT661 Series

- Main benefits
- **High flexibility** – For gentle suction and handling workpieces of different sizes, shapes, weights and/or materials
  - **Mark-free transport** – With minimised workpiece contact
  - **Minimal installation and maintenance.**

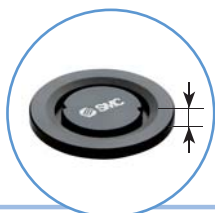

### Low profile cyclone type

- Greatly reduced thickness and increased lightness
- Suitable for being mounted on a robot arm.

Maximum detection distance:  
10 mm

Grease-free

Can be disassembled and the inside cleaned

### With multi-port

The presence of a workpiece can be checked by installing a sensor.



### Two working principles result in two gripper types

Cyclone type - air is discharged in the whirling direction

- Air savings with cost savings
- Large suction area and even pressure dispersion
  - High lifting force - up to 44 N lifting force - with low air consumption

### Bernoulli type - air is discharged radially

- Safer workpiece transfer with reduced vibration
- Available in round and square shape
  - Amplitude of the workpiece during gripping reduced
  - Reduction of rotation load due to non-directionality of whirlwind air.

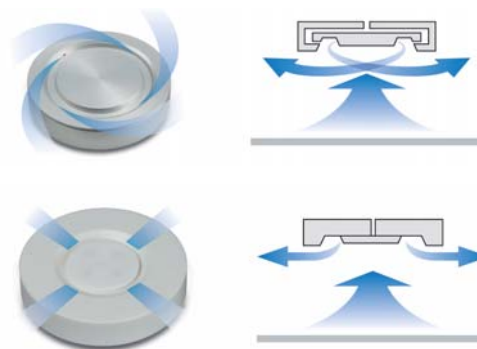

### Application examples

Non-contact transfer, for workpieces with holes, with uneven and/or viscous surface, or thin/air-permeable workpieces among others



Non-contact transfer with a robot arm



More information on the XT661 series?



<http://XT661.smc.eu/en>

# The all-in-one silent energy saving solution

## Vacuum Unit, Vacuum Ejector & Vacuum Pump System **ZK2 Series**

Main benefits

- **Achieve efficiency** – Ejector, pump and manifold system in a single unit
- **Lower your air consumption** – Energy saving digital vacuum switch and a 2-stage ejector
- **Get compactness and lightness** – Ideal solution for moving tools
- **Make your work place quieter** – Through-hole silencer.

**New**

All-in-one design with integrated components results in compactness and lightness

Versatile configuration with vacuum unit variations:

**Single unit vacuum ejector**

Individual, bracket mounting, DIN rail mounting

**Single unit vacuum pump system**

Individual, bracket mounting, DIN rail mounting

**Manifolds up to 10 stations with different wiring options: D-sub connector, flat ribbon cable, individual wiring**

With or without DIN rail mounting.

**Easy maintenance:**

Transparent filter case for visual inspection

Installation of filter element and sound absorber without screws

Possible to remove and clean the filter case in case of dirt inside

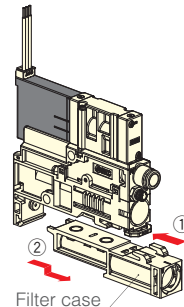
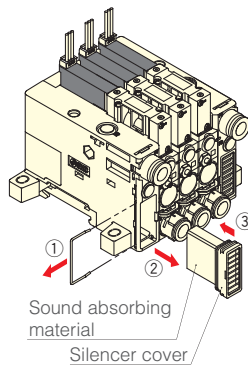
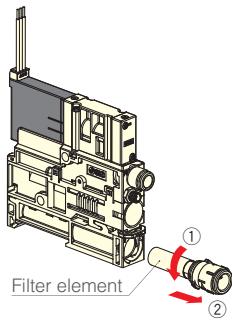

**Digital pressure switch for vacuum with energy saving function**

- More than 90 % air consumption reduction
- Not available for vacuum pump system.



**The Expert's opinion:**

*Bearing in mind the fact, that vacuum applications can be rather air inefficient, we have designed this solution to tackle the problem and substantially reduce air consumption.*

MR. MARINO COLOMBO, PRODUCT MANAGER, SMC ITALY.



### Dual 2 port valve (release valve / supply valve)

- Supply valve with self-holding function (except for energy-saving digital pressure switch option)
- Interlink between supply valve and release valve
- Power saving pilot valve (0.35 W).

### Efficient two-stage ejector

- Air consumption 30 % reduced compared to SMC single stage ejectors.

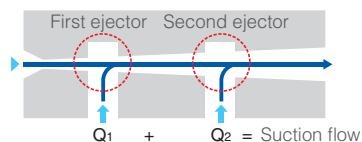

**New**



### Through-hole silencer

- Reduction of the ejector exhaust noise
- Reduction of high frequency noise
- Suction flow rate improved by up to 20 %
- The design reduces clogging caused by fine particles coming from the vacuum port.

More information on the ZK2 series?



<http://ZK2.smc.eu/en>

### Application examples

Transfer

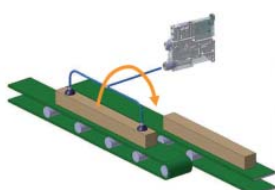

Panel conveyor

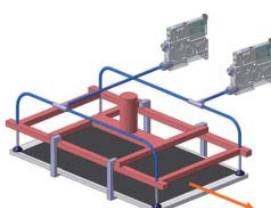

Packaging



Packaging

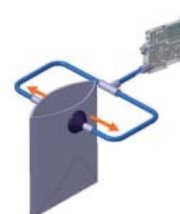

# The featherweight in vacuum generation

## Body Ported Type Vacuum Ejector **ZH Series**

Main benefits

- **Minimise the moments of inertia in mobile applications** – Weight reduction up to 74 % compared with the current model
- **Save space** – Reduced dimensions (overall length by up to 11 % and height by up to 25 %)
- **Adapt it easily to your application** – 4 mounting types available
- **Achieve great suction capacity** – Suction flow rate: up to 155 l/min (ANR).

Compact and lightweight

Length → 11 %  
 Height → 25 %  
 Weight → 74 %



Many piping variations

One-touch and screw-in combinations to choose from.

4 mounting types

Direct mounting



Standard bracket mounting



L-bracket mounting



DIN rail mounting



Easy identification of product type

Different release button colour.



Metric



Inch

Silencer and standard bracket available

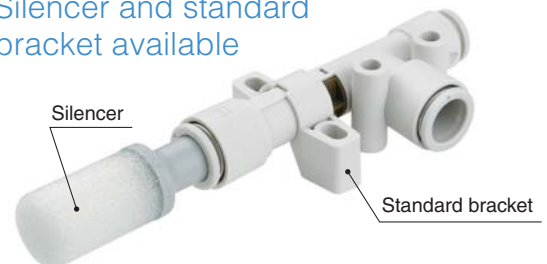

Silencer

Standard bracket

More information on the ZH series?



<http://ZH.smc.eu/en>

# Totally resistant to corrosion

## Stainless Steel Vacuum Ejector ZH-X267 Series

### Main benefits

- **Long life** – With corrosion and rust prevented thanks to its construction and materials
- **Suitable for hygienic environments** – Because it is grease-free
- **Quick identification of the product**
- It can be **easily mounted in narrow spaces**.



### Laser printing

Part number printed in the body with laser.



Manufactured entirely in stainless steel..., with compact and simple design, and free of grease and sealant

- (SCS13: equivalent to stainless steel 304)
- Maximum operating temperature: 260 °C
  - Maximum vacuum pressures: -88 kPa and -49 kPa
  - Nozzle diameters: Ø 0.5, Ø 0.7 and Ø 1.0 mm.

### Easy mounting

Provided with mounting holes for securing the body.

### Application examples

Adsorption of wet workpieces

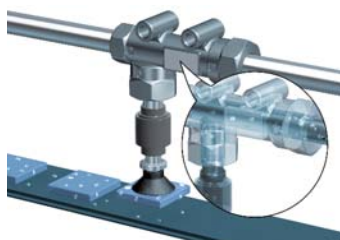

Mixing 2 types of inert gas

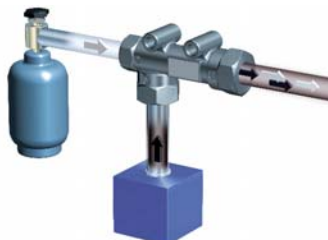

An environment where it is exposed to water



More information on the ZH-X267 series?



<http://ZH-X267.smc.eu/en>

# Lower your maintenance costs

## Aluminium High Vacuum Angle Valve **XL□-2 Series**

**Main benefits**

- **Cut your maintenance cost** – Possibility of individual bellow replacement
- **Ensure a long service life** – 2 million cycle life span for flange size 80
- **Achieve excellent resistance against fluorine corrosion** – Minimal contamination from heavy metals of semiconductor wafers
- **Use a lower capacity pump** – Low outgassing.

**Possibility of individual bellow replacement**

The bonnet assembly is prepared as a replacement part.

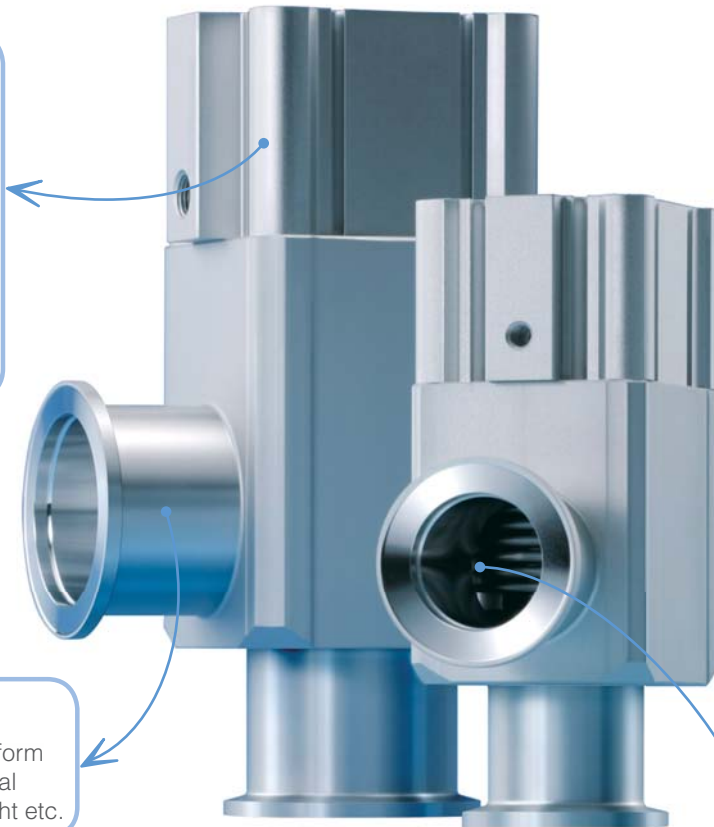

**Aluminium body**

Minimal outgassing that leads to uniform baking temperature; excellent thermal conductivity; compact and lightweight etc.

New bellows design provides long life-span

**New**

**Variety of options:**

Auto switches are mountable



Optional model with a solenoid valve



Heater available as an option

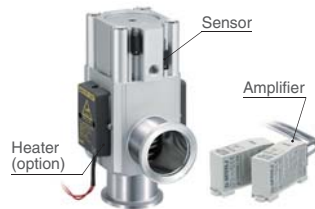

Heat-resistant 2-colour indicator solid state auto switch is available for models with a heater

More information on the XL□-2 series?



<http://XLA.smc.eu/en>

# The valve you can trust in high vacuum

## Normally Closed High Vacuum Solenoid Valve **XSA Series**

Main benefits



- **Use it in high vacuum** – Low minimum operating pressure
- **Trust it** – High sealing and minimal leakage
- **Attain flexibility** – Face seal fitting, compression fitting and female thread available.

### High sealing, minimal leakage

- Sealing performance has been improved with a larger spring
- Internal leakage:  $1.3 \times 10^{-9}$  Pa m<sup>3</sup>/s
- External leakage:  $1.3 \times 10^{-11}$  Pa m<sup>3</sup>/s

Minimum operating pressure:  
 $1 \times 10^{-6}$  Pa (abs)

### 2 types of fittings

Compression fitting



Face seal fitting



Female thread (Rc, NPT)



Application examples

Photovoltaic cell manufacturing



Semiconductor manufacturing

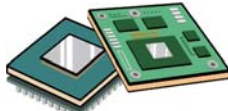

LCD manufacturing



Medical



Food



More information on the XSA series?



<http://XSA.smc.eu/en>

# Efficiency, or just making your life more pleasant

Some of us do remember the “floppy disc days”, when information was shared on those square, black devices. Nowadays this seems so archaic. In 2017 we use different online software and wireless technologies to share information quickly and securely. Furthermore, online programs and applications are a natural part of our daily lives: we wake up and check the news thanks to them; use them to control our exercise routine or social media to catch up with our friends.

Software and apps were born to enhance our lives and make them more pleasant, in all possible ways.

With that in mind, we have expanded and enhanced our software, our engineering tools, just to make the design of your machine more agreeable.



## Over 20 e-Tools to make your design experience more pleasant and efficient

In the past months, we have released up to 12 new online tools and have upgraded some of the existing ones. With more than 20 support e-tools, free of charge, we are sure you will find good support in them.

What's more, our commitment towards developing new e-tools, and enhancing the existing ones, will continue in the forthcoming months. Keep an eye on the Engineering Tools section of our Web.

## Over-sizing and over-over-sizing

Conservative engineering practices often focused on minimising capital costs or the chances of system failure, a trend to create the rounding up practices where maintenance, energy and bottom-line costs are not fully considered.

Everybody knows, that to account for various frictions and losses, it is recommended to over-size pneumatic systems by 25 %. But if we apply another 25 % to that 25 % for the “just in case”, we go from a safety margin to pure inefficiency.

## The right size matters – The Selectors

There are several types, sizes, and variations of cylinders, valves, and other automation components. You've got off-the-shelf versions and custom designs.

Aware of the fact that the sheer number of choices can be overwhelming, we have developed a series of selectors to lead, to ease your choice and to make sure you choose the exact size you need. No more.

In the event you need to select components for a complete pneumatic actuation circuit, we put the Model Selection Software at your disposal; it includes the most common references for SMC valves, connectors and actuators





## When a guided tour makes the visit nicer – The Configurators

Combining components in complex assemblies can sometimes be an overpowering experience. Our Configurators will make your life easier and your projects stronger when integrating FRL units, valves manifolds or customised cylinders.

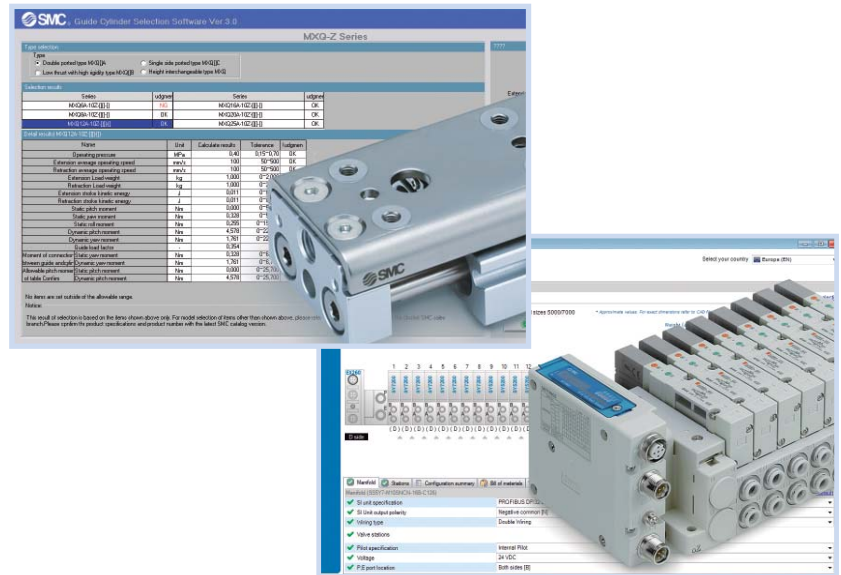

## Time is gold – The Calculators

We reckon your time is too precious to be spent in doing endless manual calculations. That is why we have developed several calculators with a user-friendly interface which, in just a few steps, will do them for you. Besides, with them, potential errors are avoided.

From a “simple” calculation of the moments of inertia to the required air flow capacity for complex systems; with a stop at one of our preferred topics: Energy Saving. We have several e-Tools at the ready to assist you in saving time, energy and money.

In short, you will be provided with support for your most common daily calculations.

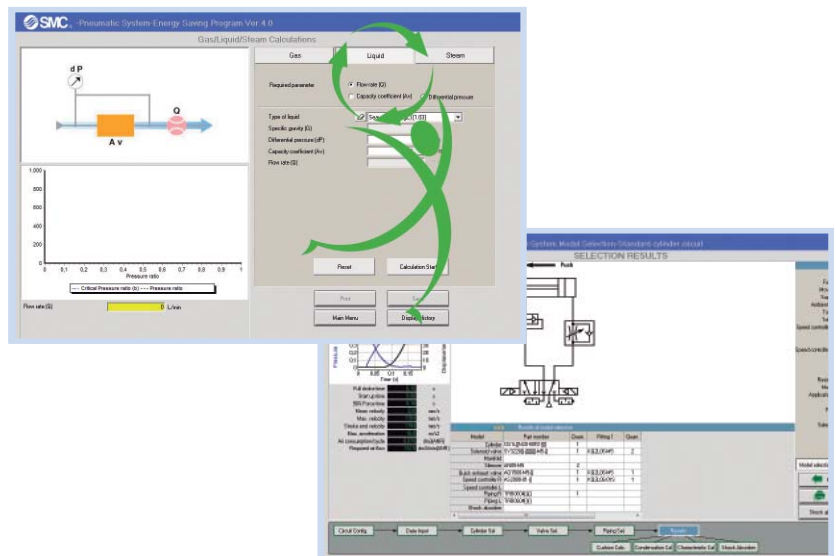

## To wrap your project up– ePlan and other support tools

Documenting your projects is another time-consuming task. SMC therefore provides further support in terms of: ePlan macros, pneumatic symbols and CAD files to speed up this part of your machine design.

Working close to you sometimes means providing you with the necessary tools for you to **work and design** on your own.

# Our most powerful electric actuator

## High-Rigidity Electric Actuator, Slider Type **LEJ Series**

Main benefits

- **Ensure robustness in your application** – Supports eccentric loads with high accelerations
- **Move your workpieces at ease** – Compact motor size ensures workpieces, even large ones, do not collide with the motor
- **Increase your productivity** – High-speed transport
- **Reduce installation time** – Easy mounting of the main body.

Low profile and low centre of gravity

Workpiece does not interfere with the motor, as table height is greater than motor height.

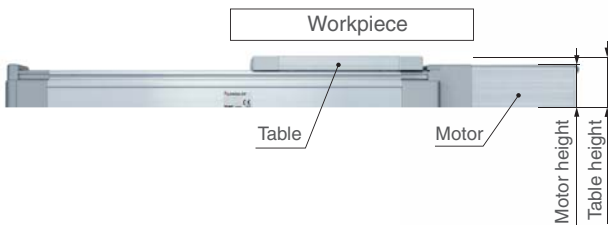

Dustproof construction, as it is equipped with a seal band as standard

The seal band covers the guide, thus preventing grease from splashing and external foreign matter from entering.

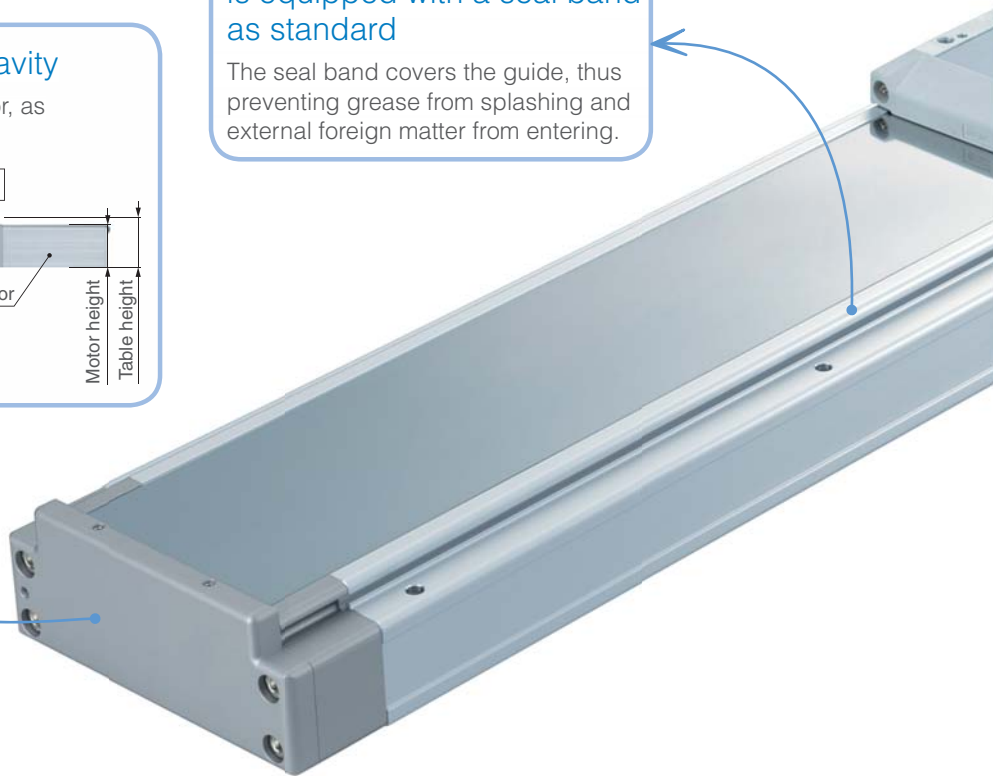

Double axis linear guide construction provides high-precision and high-rigidity  
 Even further improved position repeatability and lost motion with the high-precision type, series (11-)LEJSH

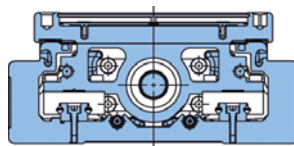

Linear guide (Double axis)

Position repeatability:  $\pm 0.01$  mm  
 Lost motion: 0.05 mm

Compatible drivers: AC Servo Motor LECSA/LECSB/LECSB/LECSS/LECYM/LECYU



The Expert's opinion:

*LEJ meets the needs of those applications requiring a solid and robust actuator. In simple terms, it's been designed to move heavy loads with absolute precision.*

MR. ANDREA TRIFONE, PRODUCT & PROJECT MANAGER - ELECTRICAL ACTUATORS, SMC ITALY

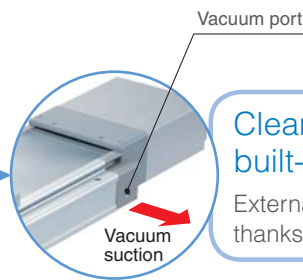
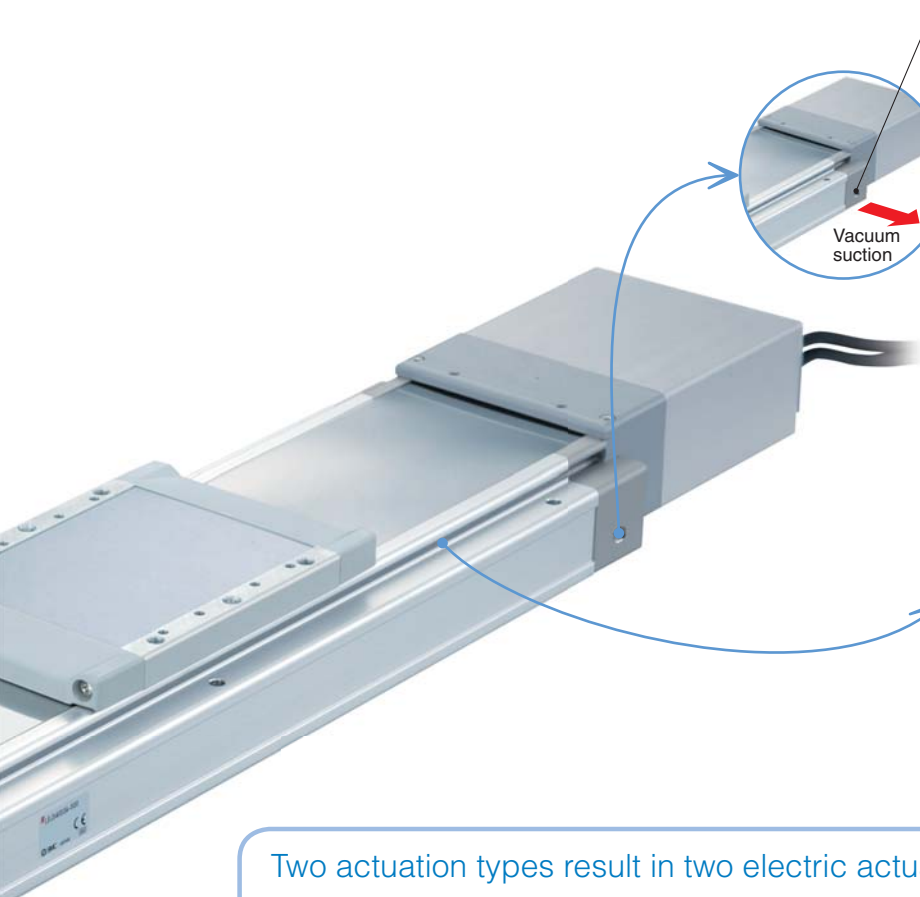

**Clean Room Specification with built-in vacuum piping (11-LEJS)**  
 External particle generation minimised thanks to vacuum exhaust.

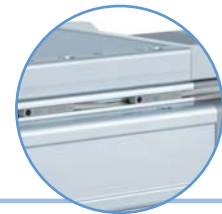

**Perfect for use with 2-colour indication solid state auto switches series D-M9 and D-M9W**

**Two actuation types result in two electric actuator types**

<p><b>Ball Screw Drive LEJS</b> - suitable for repeatable accurate positioning</p> <ul style="list-style-type: none"> <li>- Max. workload: 85 kg (horizontal)</li> <li>- Positioning repeatability: <math>\pm 0.02</math> mm</li> <li>- Max. stroke: 1500 mm</li> <li>- Max. speed: 1800 mm/s</li> <li>- Max. acceleration/deceleration: 20000 mm/s<sup>2</sup></li> </ul>	<p><b>Belt Drive LEJB</b> - suitable for long-stroke high-speed and light-load transfer</p> <ul style="list-style-type: none"> <li>- Max. workload: 30 kg (horizontal)</li> <li>- Positioning repeatability: <math>\pm 0.04</math> mm</li> <li>- Max. stroke: 3000 mm</li> <li>- Max. speed: 3000 mm/s</li> <li>- Max. acceleration/deceleration: 20000 mm/s<sup>2</sup></li> </ul>
--	---



Ball screw

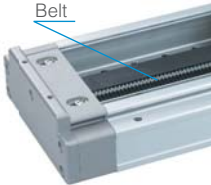

Belt

**Application examples**

**Pick and place**  
 Recommended driver: LECSS□

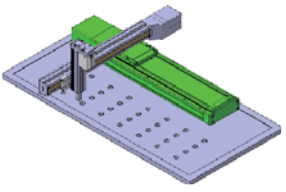

**Glue dispensing/high speed trajectory is available**  
 Recommended driver: LECSS (SSCNET III)

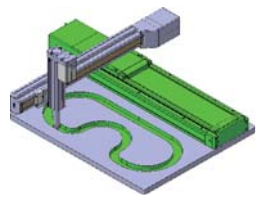

More information on the LEJ series?



<http://LEJ.smc.eu/en>

# Empowers you to choose freely

## Electric Actuators, Motorless Type **LEF, LEJ, LEY(G) Series**

Main benefits

- **Build up the best possible solution for you** – Use your own motor and driver
- **Make things easier** – You can apply the know-how you already have to our electric solutions
- **Optimise your application** – Motors from 15 companies to choose from.

Compatible with 100/200/400 W motors of main manufacturers

- OMRON Corporation
- Siemens AG
- Beckhoff Automation GmbH
- YASKAWA Electric Corporation
- Panasonic Corporation
- Delta Electronics, Inc.
- FANUC Corporation
- FASTECH Co., Ltd.
- FUJI ELECTRIC CO., LTD.
- KEYENCE Corporation
- Mitsubishi Electric Corporation
- NIDEC SANKYO Corporation
- Rockwell Automation, Inc. (Allen-Bradley)
- SANYO DENKI CO., LTD.
- ORIENTAL MOTOR Co., Ltd.



More information on the LE motorless series?



<http://LE.smc.eu/en>

Available series with no motor attached: LEFS, LEFB, LEJS and LEY(G)

**LEFB/LEFS**



**LEJS**



**LEY**



**LEYG**



# Looking for an enduring electric actuator? Search no more

## Rod Type Electric Actuator, Dust/Drip Proof Specification **LEY-X5 Series**

Main benefits

- **Lifespan increased** – With IP65 Enclosure Protection
- **Operator safety increased** – Thanks to the motor cover
- **Cable breakage reduction.**

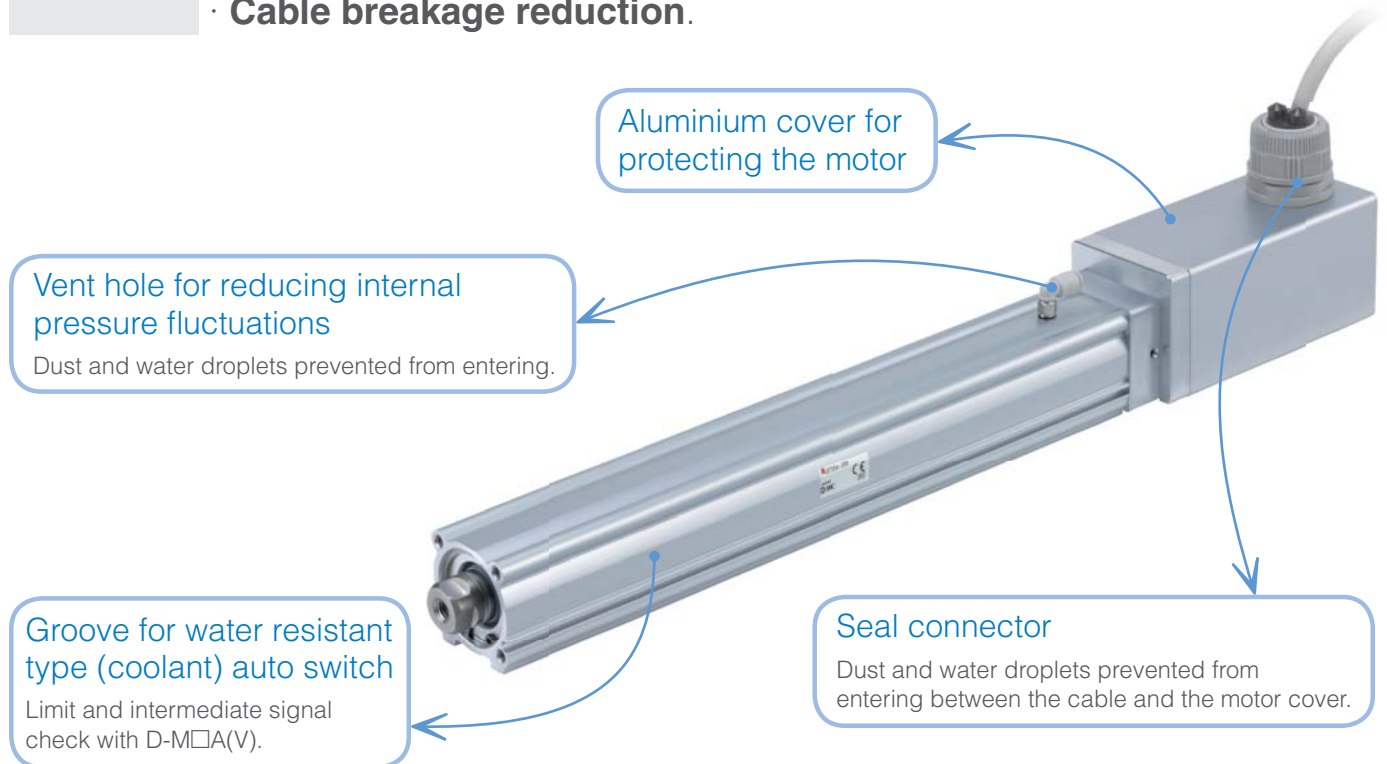

### Selectable motor type and motor mounting

DC Step/Servo Motor  
In-line motor type



DC Step/Servo Motor  
Top-mounting motor type



AC Servo Motor  
In-line motor type



AC Servo Motor  
Top-mounting motor type



Application examples

Lifter



Pushing and repelling operation

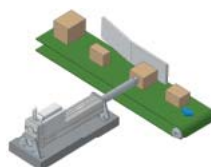

Delivery

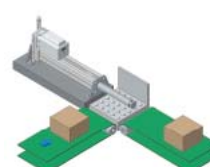

Press fitting



More information on the LEY-X5 series?



<http://LEY-X5.smc.eu/en>

# Solution for narrow spaces and heavy workloads

## Low Profile Guide Slider Electric Actuator **LEM Series**

Main benefits

- **Space savings** – Suitable for use in narrow and reduced spaces
- **Productivity increase with cycle time reduction**
- **Cost and labour savings** – With reduced maintenance and machine stops, and with end-to-end operation similar to an air cylinder
- **Easy to control** – Positions with the possibility of mounting auto switches.

The drive unit and guide unit are separable (not LEMB)

Easy attachment / detachment.

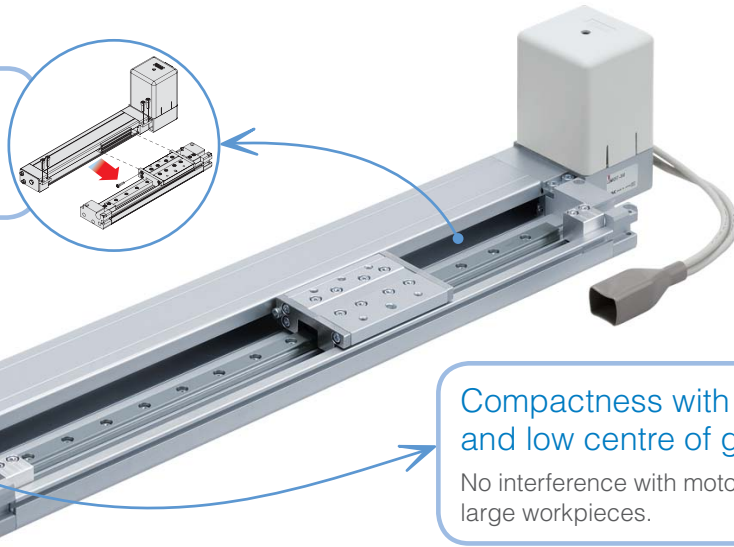

Compactness with low profile and low centre of gravity

No interference with motor even with large workpieces.

### Selectable guide mechanism, step motor mounting direction and control method

**Guide mechanism:**

LEMB  
Basic type

LEMC  
Cam follower type

LEMH  
Linear guide single shaft type

LEMHT  
Linear guide double shaft type



**Motor mounting direction:** top/bottom, right/left

**Control method:** LECP1, LECP2 (specific controller for LEM with stroke study function that automatically registers both end positions), LECP6.

Application examples

Load and unload transfer of workpieces

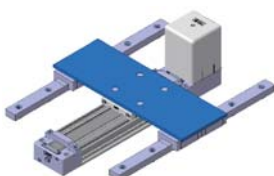

Pick and place (applications where space is limited)

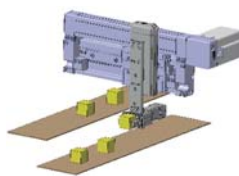

More information on the LEM series?



<http://LEM.smc.eu/en>

# Broader & safer control

## Step Motor Controller **JXCE1/91/P1/D1 Series**

### Main benefits

- **Ease off your fieldbus network** – Only one unit for directly operating an electric actuator through fieldbus
- **Save money, time and labour** – Simplified control systems and wiring
- **Increase the security of your communications** – No loss of communication despite having a disconnected location.

### Direct operation through a fieldbus network

• Applicable fieldbus protocols:

**EtherNet/IP** **EtherCAT** **DeviceNet** **PROFINET**

- 10/100 Mbps high-speed communication
- Two types of operation command:
  - Step number defined operation
  - Numerical data defined operation
- Real time operation.

### Dual port connection, IN and OUT

This allows for different topologies:

#### • Linear topology:



#### • Device Level Ring (DLR) topology:

Ensures no loss of communication despite having a disconnected location.

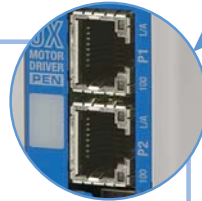
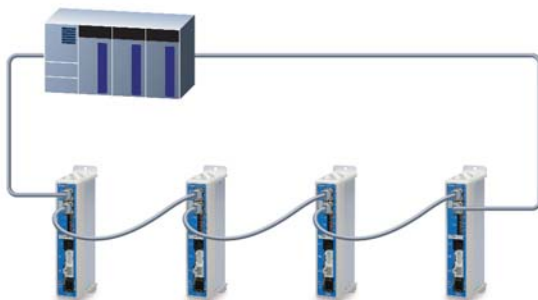

Compatible electric actuators: LEY(G), LEFS/LEFB, LES(H), LER, LEL, LEPY/LEPS, LEH, LEM



More information on the JXCE1/91/P1/D1 series?



<http://JXCE91.smc.eu/en>

# Quadruple your control

## 4 Axis Step Motor Controller **JXC73/83/93 Series**

Main benefits

- **Simplify the programming** – Set up to 4 axes at once, in just one connection
- **Minimise the amount of equipment and wiring**
- **Create a comprehensive solution** – Control single or multiple axes with a single product. Available in both types, Parallel I/O and EtherNet/IP™.

Step data input with maximum 2048 points

**Absolute/relative** position coordinates instructions.  
**Positioning/pushing** operation.

2 models for communicating

**JXC93 - EtherNet/IP™ type**  
 (direct connection to a fieldbus network)

**JXC73/83 - Parallel I/O**

EtherNet/IP™ cable



**EtherNet/IP™**

I/O cable



**The Expert's opinion:**

*The market was demanding a solution to perform interpolation and synchronism; this facilitates our customers' programming tasks greatly. JXC□3 is our answer to it.*

DANIEL RELLSTAB, PRODUCT MANAGER ELECTRICAL ACTUATORS, SMC SWITZERLAND



## Approximation to linear and circular interpolation for XYZ and XY axes respectively

- Linear interpolation available for the 3 axes, XYZ
- Arc interpolation available for the X and Y axes only, XY.

Linear interpolation

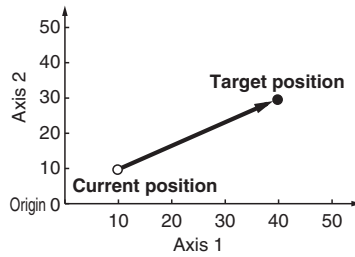

Circular interpolation

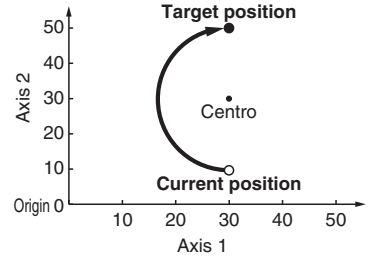

## Direct operation of up to 4 electric actuators with only one controller, for either single or multiple axes

- **4 axis operation** can be set collectively in one step
- **4 axis synchronous** control.

## Compatible electric actuators: LEY(G), LEFS/LEFB, LES(H), LER, LEPY/LEPS, LEH



## More information on the JXC73/83/93 series?



<http://JXC73.smc.eu/en>

## Application examples

- **Pick and place**, either in linear or arc interpolation

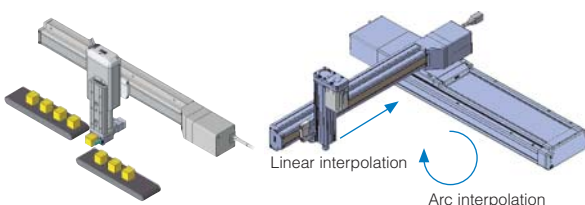

- **Vertical board lifting** – to vertically lift/lower a board with four electric actuators simultaneously, so that the board remains horizontal all the time

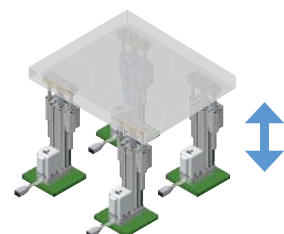

# Complete in its capacities, simple in its adjustment

## AC Servo Motor Controller, Pulse Input Type **LECS Series**

Main benefits

- **Productivity increase** – With high working rate
- **Cycle time reduced** – With better performance in positioning
- **Production safety and quality improved** – Through easy alarm monitoring
- **Cost and labour savings** – Through less wiring
- **Improved robustness against noise.**

With display setting function

Allows for monitoring and setting different parameters/values depending on the model.



Compatible electric actuators: LEY(G), LEF, LEJ

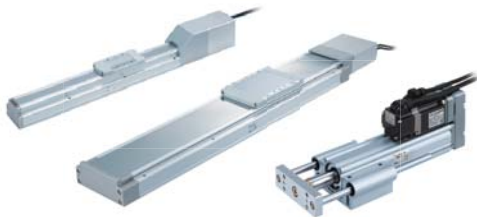

Several types to suit requirements

- LECSA** (Pulse input type for incremental encoder): Positioning type, with up to 7 positioning points by point table
- LECSB** (Pulse input type for absolute encoder): 10/6 parallel inputs/outputs
- LECS C** (CC-Link direct input type for absolute encoder): Suitable for multipoint positioning, being possible to set position data/speed data and operation start/stop
- LECSS** (SSCNET III type for absolute encoder): Optimum for interpolation and with enhanced noise resistance by using fibre optics for communication
- LECSS-T** (SSCNET III/H type for absolute encoder): Optical communication protocol with STO - Safe Torque Off - function (in accordance with IEC61800-5-2) and homing done by Z-phase, ideal for machines with axis motion.

More information on the LECS series?



<http://LECS.smc.eu/en>

# High performance for highly demanding applications

## AC Servo Motor Driver, MECHATROLINK Compatible **LECY Series**

### Main benefits

- **Enhanced safety** – Preventing the drive from restarting unexpectedly
- **Wiring, material and labour savings** – With no need for separate components and simpler positioning with no need for auto switches
- **Suitable for interpolation in axis motion**
- **Improved productivity and accuracy** – With high working rate and better performance in positioning.



Lock cable integrated with motor cable

**STO - Safe Torque Off - function in accordance with IEC61800-5-2**

Drive prevented from restarting unexpectedly, providing quicker responses than conventional solutions.

**Compatible electric actuators: LEY(G), LEF, LEJ**



Position control, speed control and torque control can be achieved

Homing can be performed by mechanical end stop

Simple positioning possible without need for external auto-switches

**Product variation:**

**LECYM Series (MECHATROLINK-II Type)**

- Number of connectable drivers: 30 units
- Transmission distance: maximum 50 m (in total)
- Maximum communication speed: 10 Mbps
- Minimum communication cycle: 250  $\mu$ s.

**LECYU Series (MECHATROLINK-III Type)**

- Number of connectable drivers: 62 units
- Transmission distance: maximum 75 m (between stations)
- Maximum communication speed: 100 Mbps
- Minimum communication cycle: 125  $\mu$ s.

More information on the LECY series?



<http://LECY.smc.eu/en>

# Your small solution for transport, push & measurement

## Card Motor **LAT3 Series**

Main benefits

- **Save space** – Unique miniature 3-in-1 solution for transport, pushing and measuring
- **Increase your productivity** – High-speed response
- **Operate it easily** – Put it to work by just inputting 3 parameters
- **Get a compact solution with great transfer capabilities** – Maximum horizontal load of 1 kg.

3 functions in 1 unit

Transportation, pushing and measurement systems have been miniaturised through the use of a linear motor.

- Maximum pushing force:** 6 N
- Position repeatability:**  $\pm 5 \mu\text{m}$
- Pushing measurement accuracy:**  $\pm 10 \mu\text{m}$
- Maximum horizontal load mass:** 1 kg
- Maximum operating frequency:** 500 cpm.

Easy programming and Modbus serial communication

**Cycle Time Entry Method:** Operation setting is completed by only introducing 3 parameters: target position + positioning time + workload  
**Modbus serial communication compatible.**

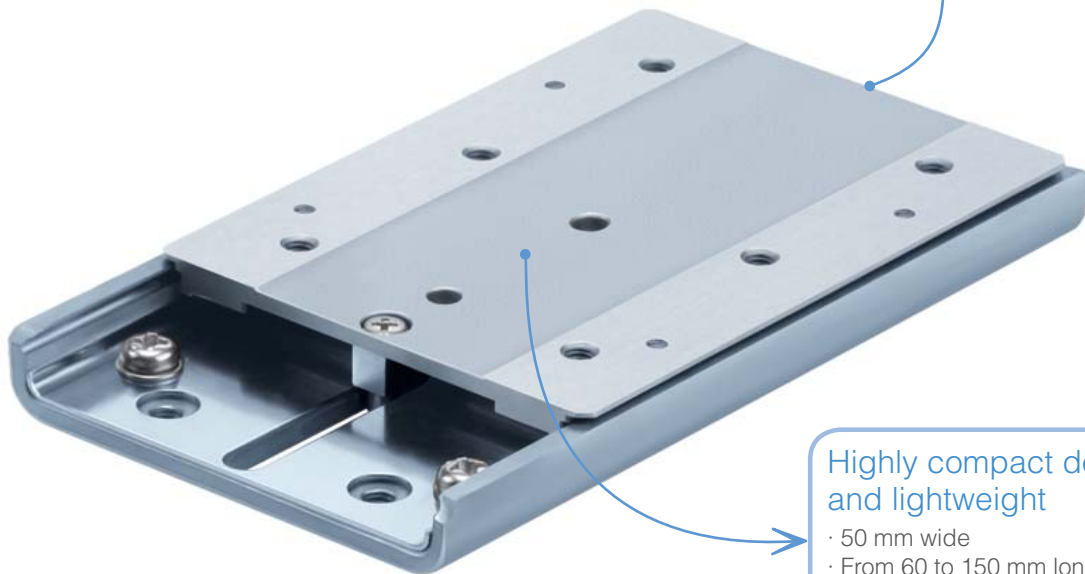

Highly compact design and lightweight

- 50 mm wide
- From 60 to 150 mm long
- From 10 to 50 mm stroke variations
- From 130 to 360 g weight.

More information on the LAT3 series?



<http://LAT3.smc.eu/en>

Application examples

Positioning of workpieces with high precision

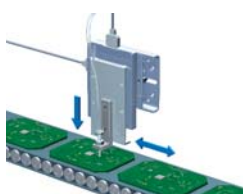

Pushing small loads

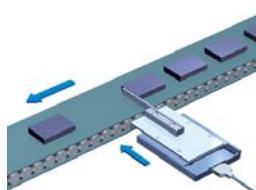

Maximum accuracy measurements

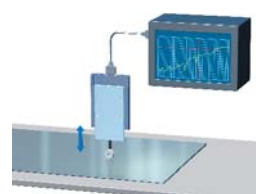

High-precision applications (high cycling frequency)

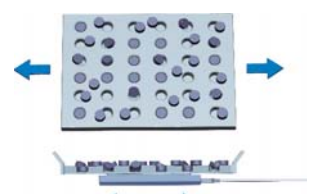

# Get control versatility for your ultra-thin actuator

## Card Motor Controller **LATCA Series**

### Main benefits

- **Directly and remotely control your LAT3 card motor**
- **Achieve versatility** – 3 types of input signals to control
- **Operate your card motor easily** – Automatic calculation of speed, acceleration and deceleration with Cycle Time Entry method.

### 3 types of input signals to work with

- **Step Data Input:** I/O for general, with 15-step data and 6/4 parallel I/O
- **Pulse Input:** with 4-step data and 6/4 parallel I/O
- **Serial Input** (based on Step Data Input): allows the connection in series of up to 16 controllers via RS485. The protocol is specific to LATCA



A controller setting kit is required for configuring any of the different control methods of the LATCA.

### Compatible electric actuator: LAT3



Communication cable is common to both LATCA and LEC controllers



More information on the LATCA series?



<http://LATCA.smc.eu/en>







Expertise – Passion – Automation

### SMC Corporation

Akihabara UDX 15F, 4-14-1  
Sotokanda, Chiyoda-ku, Tokyo 101-0021, JAPAN  
Phone: 03-5207-8249  
Fax: 03-5298-5362



<http://innovation-17.smc.eu/en>

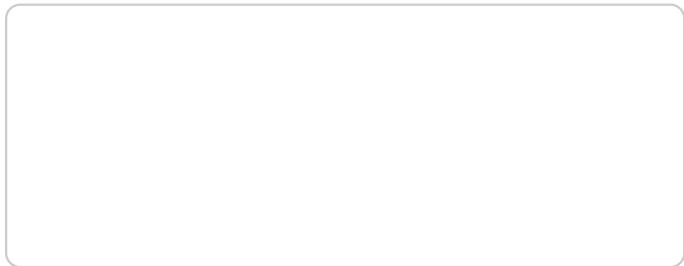

### www.smc.eu

<b>Austria</b>	+43 (0)2262622800	www.smc.at	office@smc.at
<b>Belgium</b>	+32 (0)33551464	www.smcpnematics.be	info@smcpneumatics.be
<b>Bulgaria</b>	+359 (0)2807670	www.smc.bg	office@smc.bg
<b>Croatia</b>	+385 (0)13707288	www.smc.hr	office@smc.hr
<b>Czech Republic</b>	+420 541424611	www.smc.cz	office@smc.cz
<b>Denmark</b>	+45 70252900	www.smc.dk.com	smc@smcdk.com
<b>Estonia</b>	+372 6510370	www.smcpnematics.ee	smc@smcpneumatics.ee
<b>Finland</b>	+358 207513513	www.smc.fi	smc.fi@smc.fi
<b>France</b>	+33 (0)164761000	www.smc-france.fr	info@smc-france.fr
<b>Germany</b>	+49 (0)61034020	www.smc.de	info@smc.de
<b>Greece</b>	+30 210 2717265	www.smchellas.gr	sales@smchellas.gr
<b>Hungary</b>	+36 23513000	www.smc.hu	office@smc.hu
<b>Ireland</b>	+353 (0)14039000	www.smcpnematics.ie	sales@smcpneumatics.ie
<b>Italy</b>	+39 0292711	www.smcitalia.it	mailbox@smcitalia.it
<b>Latvia</b>	+371 67817700	www.smclv.lv	info@smclv.lv

<b>Lituania</b>	+370 5 2308118	www.smclt.lt	info@smclt.lt
<b>Netherlands</b>	+31 (0)205318888	www.smcpnematics.nl	info@smcpneumatics.nl
<b>Norway</b>	+47 67129020	www.smc-norge.no	post@smc-norge.no
<b>Poland</b>	+48 222119600	www.smc.pl	office@smc.pl
<b>Portugal</b>	+351 226166570	www.smc.eu	postpt@smc.smces.es
<b>Romania</b>	+40 213205111	www.smcromania.ro	smcromania@smcromania.ro
<b>Russia</b>	+7 8127185445	www.smc-pneumatik.ru	info@smc-pneumatik.ru
<b>Slovakia</b>	+421 (0)413213212	www.smc.sk	office@smc.sk
<b>Slovenia</b>	+386 (0)73885412	www.smc.si	office@smc.si
<b>Spain</b>	+34 902184100	www.smc.eu	post@smc.smces.es
<b>Sweden</b>	+46 (0)86031200	www.smc.nu	post@smc.nu
<b>Switzerland</b>	+41 (0)523963131	www.smc.ch	info@smc.ch
<b>Turkey</b>	+90 212 489 0 440	www.smcpnomatik.com.tr	info@smcpnomatik.com.tr
<b>UK</b>	+44 (0)845 121 5122	www.smcpnematics.co.uk	sales@smcpneumatics.co.uk